

# **STORM SEWER COLLECTION SYSTEM**



**(Parts V & VI)**

# **STORM**



**(Part V)**

**\* General Requirements**

## **STORM SEWER COLLECTION SYSTEM**

### **(General Requirements)**

- 1. Proposed storm sewer mains must be in accordance with the City of Troutdale's Public Facilities Plan. Main sizes must be adequately sized to handle the flow collected from the proposed development. Areas above and below the development must also be considered in design, and pipes sized accordingly.**
- 2. All construction/installation of storm sewer mains shall be done in a safe, neat and professional manner, and under supervision by City forces at all times. All safety requirements from OSHA, and other State regulatory agencies must be met.**
- 3. All requirements from DEQ must be met.**
- 4. Storm sewer design for subdivisions shall be based on a 10-year storm event in pre-development condition, and a 25-year storm event in post development conditions. Use either the rational and/or the Santa Barbara method to determine the storm water's rate of discharge and volume.**
- 5. In no case will a storm sewer pipe less than 12 inches in diameter be approved, including catch basin leads. When locating catch basins near intersections, locate them outside the wheelchair ramp area to avoid conflict. Preferred location is at either end of the curb returns. Where possible, catch basin leads must be connected to a storm sewer manhole.**
- 6. Rainfall intensity shall be based on the most current curves compiled by or for Multnomah County.**
- 7. Rainfall coefficients shall be based on the ultimate development planned or the land use shown in the City of Troutdale Comprehensive Plan.**
- 8. Maximum catch basin spacing for street slopes of 1.0 to 4.0% is 300 feet; for slopes greater than 4.0%, 500 feet.**
- 9. Provide a 7-inch curb exposure at all catch basin locations.**
- 10. Combined sanitary and storm sewers are strictly prohibited.**
- 11. Manholes shall be located at all alignment and pipe size changes, grade breaks and all street intersections, and spacing between manholes shall not exceed 300 feet.**

12. **Manholes shall have a minimum of 0.2 foot drop from pipe invert "in", to pipe invert "out", and storm lines between manholes shall meet the minimum allowable slope requirements as required by general engineering principles and DEQ's rules and regulations.**
13. **Invert elevations shall be adjusted so that pipe inverts match when pipe size changes occur at manholes. Channels are required to be poured in place as shown in the construction details section.**
14. **Pipe cover shall be 24 inches minimum from finished grade. If a shallower depth is required, pipe used must be D.I. and/or plastic encased in concrete. Either must be approved by the City during the design phase and prior to the start of construction.**
15. **Storm sewer systems shall have an outlet into a natural body of water, natural drainage channel, stream or previously constructed drain pipe, ditch, or detention facility. At the point of daylight, the daylight area must be adequately prepared to prevent soil erosion by placing rip-rap, hay bales, or other acceptable method as approved by the City (addressed in Part IX and X of these Construction Standards).**
16. **County and State permission is required to discharge into any County or State storm drain or roadside ditch. Whenever projects affect the jurisdiction of other agencies, a copy of the work permit and/or written authorization from those agencies is required by the City.**
17. **Dry wells are permitted only where shown on Drawing VI-10, and after soil tests (performed by a registered soils engineer) show that soils are suitable for subsurface disposal of storm water. Test results must be submitted to the City in writing for review and approval. Drywells shall not be allowed if a nearby storm main exists. The City must determine when drywells may or may not be constructed.**
18. **Minimum diameter allowed for storm sewer mains (including catch basin leads) shall be 12 inches and of concrete or ADS N-12 only. Compatible ADS N-12 fittings must be used with ADS N-12 storm pipe. Location of the storm sewer mains in the streets must be no less than five feet from the sanitary sewer and/or street centerline on the north and west sides of the sanitary sewer and/or street's centerline. See Drawing II-21 for further detail.**
19. **Minimum diameter allowed for storm laterals shall be 6-inches and of concrete or ADS N-12 only. All laterals shall be properly marked at ends as shown on Drawing VI-7.**
20. **All new storm sewer pipes and manholes must be thoroughly cleaned and pressure tested as required by the City. All tests must be witnessed and passed by the City prior to placing these facilities into operation. All ADS-N-12 pipe used must be of water-tight joints and may be pressure tested if so required by the City.**

21. **Connection to storm sewer mains with private storm sewer laterals hooked up to swimming pools, or other structures which may contain high contents of chlorine mixtures is strictly prohibited. Such materials, and all others which may contain strong chemical mixtures of any kind, shall be discharged directly into the sanitary sewer only. Approval to discharge such materials into the sanitary sewer must be pre-approved by the City.**
22. **All connections to existing storm sewer mains require issuance of a public works permit and inspection by the City prior to backfilling. A permit fee of \$50.00 will be assessed for each connection/inspection.**
23. **If the slope of the land prevents lot surface and rain drain storm water from draining to the street through a curb weep hole, a private storm water lateral must be provided by the developer/property owner, and marked as required if connection to the house will not be made at the same time.**
24. **Public storm sewer lines within streets will only be installed in public rights-of-way. Any storm sewer line installed within private streets will be privately owned and maintained. Public responsibility for the storm sewer collection system stops at the sewer main and does not include laterals to individual properties.**
25. **All public storm sewer mains extending into, under, above, through and beyond private property, shall be placed within a legal public utility easement granted to the City by the affected property owner(s). Width and length of such easement will be determined by the City, and will be based on size, type, depth and length of pipe being used. Building Code restrictions, as they apply to public utility easements, shall apply.**
26. **The builder/developer must provide to the City any guarantee or warranty normally furnished with the purchase of any materials used in connection with the project at hand. In addition, they must furnish the City a written warranty providing satisfactory in-service operation of all work performed by affected contractor (including but not limited to all storm mains, laterals, manholes, catch basins, grates, etc.) for a period of two (2) years following date of project acceptance.**
27. **All other construction practices (relating to storm sewer) within the City's public right-of-way, not covered in these "General Requirements" and/or "Construction Details" sections, shall comply with the rules and regulations found in the most recent edition(s) of the American Public Works Association Standard Specifications for Public Works Construction.**
28. **All new improvements proposed for construction and intended for public dedication (once these facilities are constructed to City standards) must be proposed to the City in writing, by the developer and/or legal owner of the project, prior to the receipt of an**

**authorization to begin construction from the City. This formal written request from the developer/owner to the City must be reviewed and approved by the City, and then signed by both parties to formally bind both parties to the agreement.**



# **STORM**



**(Part VI)**

**\* Construction Details**

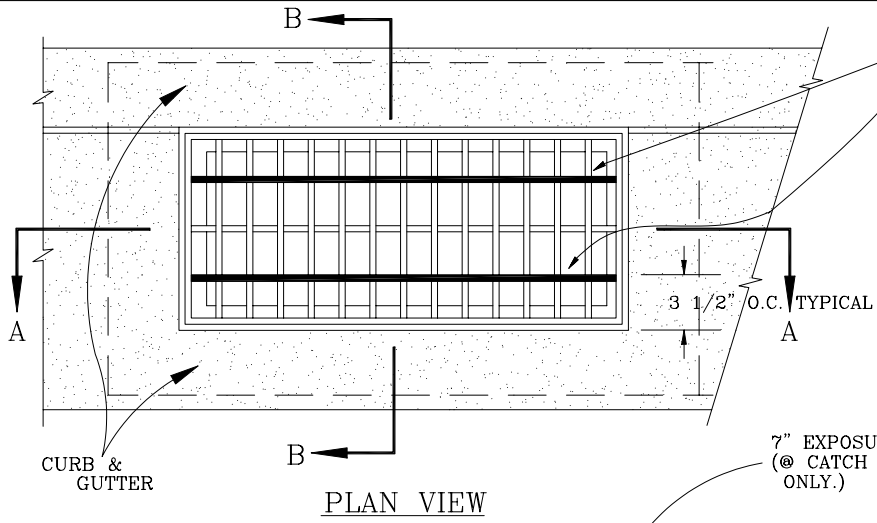

WELD TWO BICYCLE PROOF BARS  
1" X 1/4" X 36", AS SHOWN

**GENERAL NOTES:**

1. CATCH BASIN MUST BE LOCATED OUTSIDE THE HANDICAP RAMP TO AVOID CONFLICT.
2. CONCRETE SHALL BE 3000, PSI, @ 28 DAYS.
3. ONLY CONCRETE MATERIAL SHALL BE USED FOR CONSTRUCTING CATCH BASINS.
4. CONNECT CATCH BASIN LEADS TO STORM MANHOLES WHEREVER POSSIBLE.
5. CATCH BASIN LEADS SHALL BE A MINIMUM OF 12 INCHES IN DIAMETER.
6. CATCH BASINS MUST BE PROTECTED FROM SILT AND SOIL EROSION BY USE OF BIO-FILTER BAGS (OR EQUAL) UNTIL THE SECOND LIFT OF A.C. IS PLACED.

PLAN VIEW

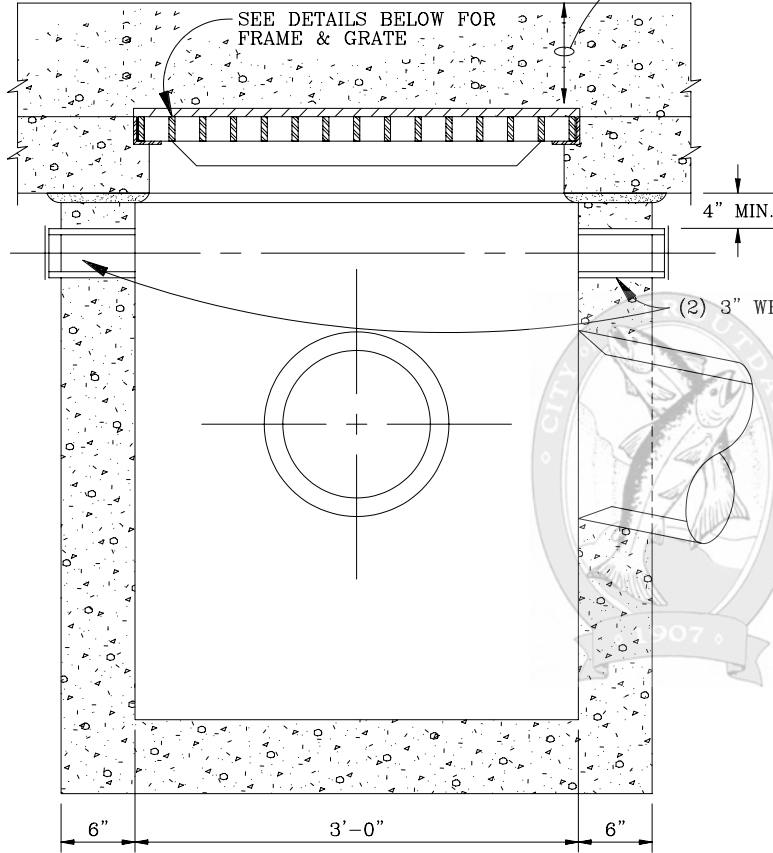

SECTION A-A

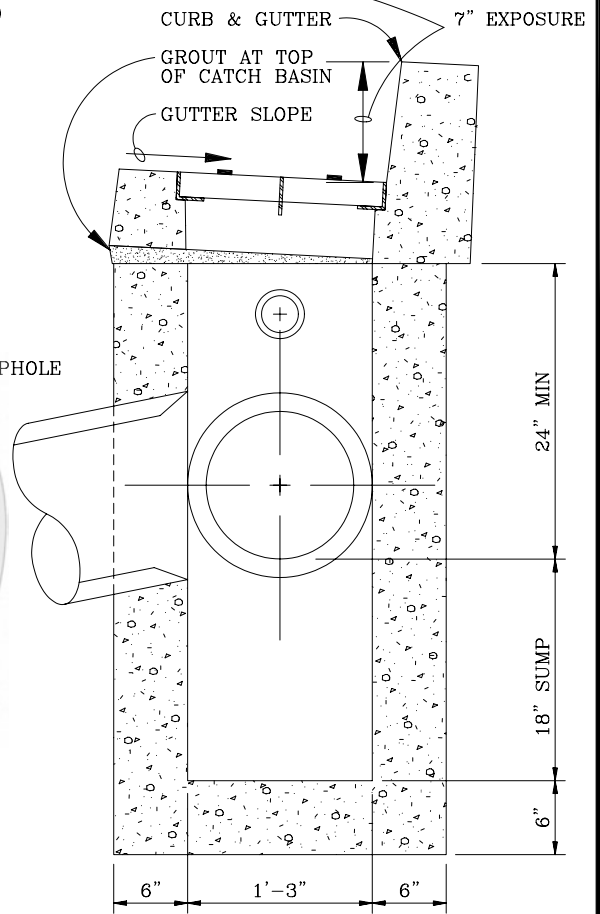

SECTION B-B

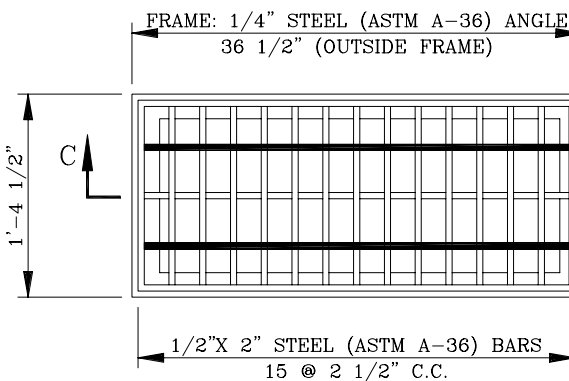

WELDED STEEL FRAME AND GRATE PLAN

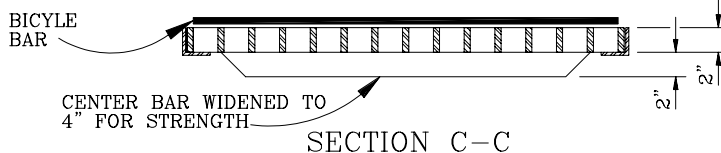

SECTION C-C

ALL CORNERS OF GRATE BARS TO BE WELDED WITH 1/4" TYP AWS

- 3 @ 7 1/2" C.C.
- (2) 1/2" X 2" X 36" EDGE BARS.
- (1) 1/2" X 4" X 36" MIDDLE BAR.

CITY OF TROUTDALE

*CATCH BASIN*

DATE:  
UPDATED 1997

DRAWING NO.  
VI - 1

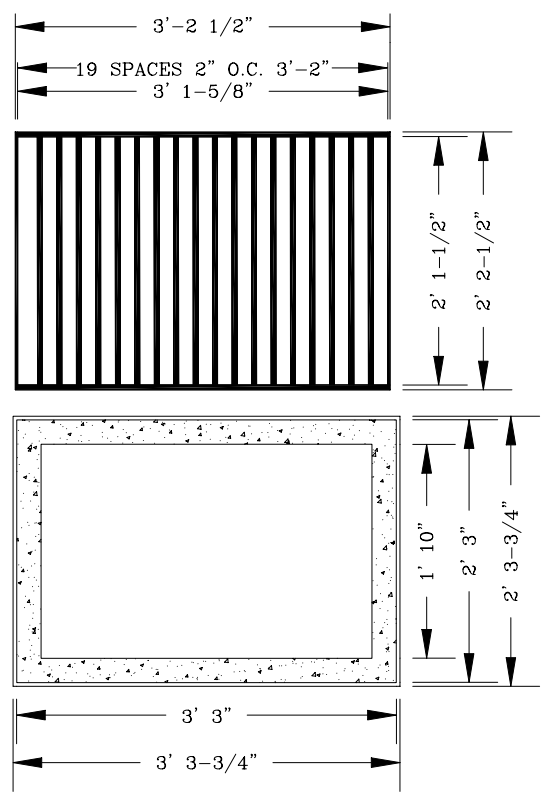
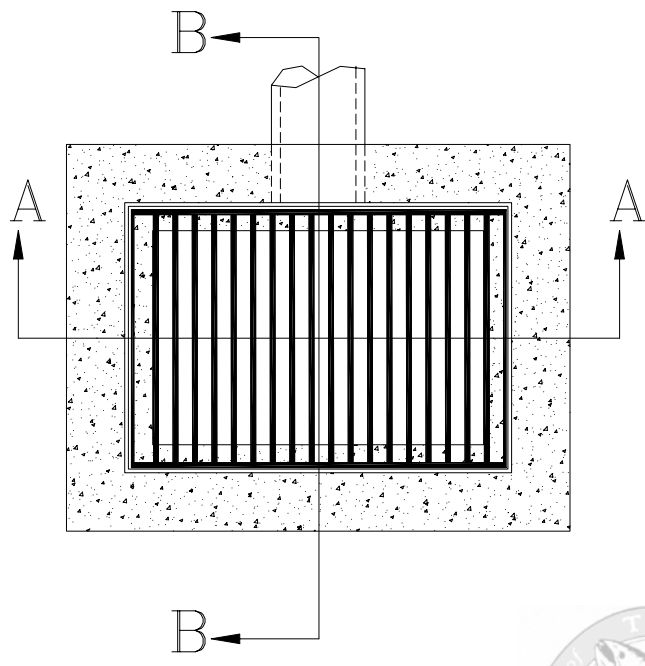

FRAME AND GRATE DETAIL

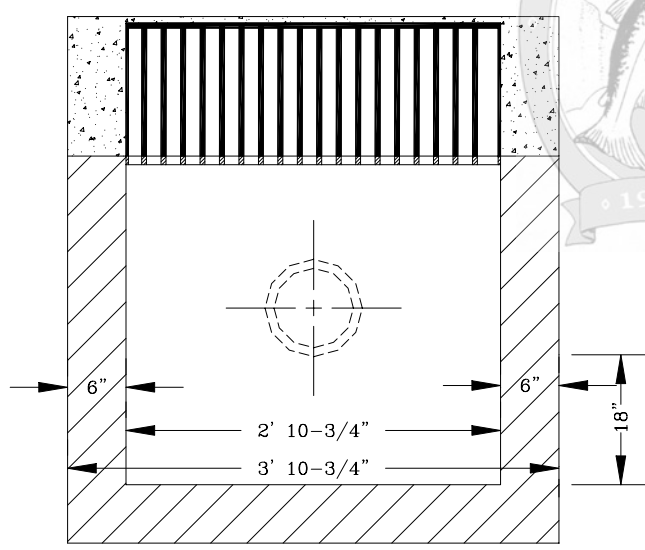

ELEVATION A-A

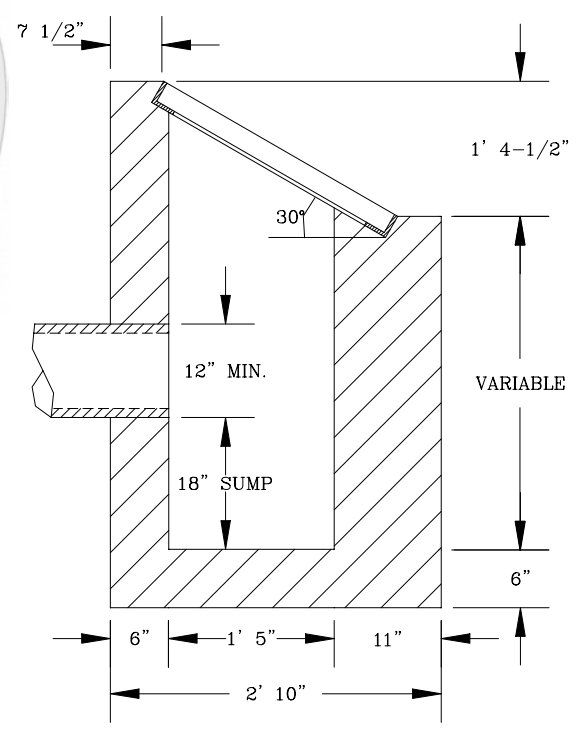
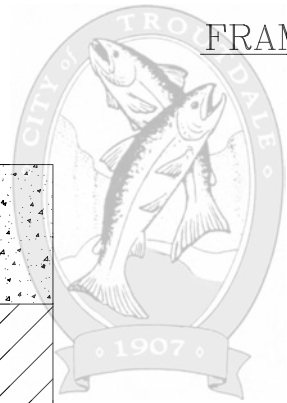

SECTION B-B

CITY OF TROUTDALE

*DITCH INLET*

GENERAL NOTES:

1. EROSION CONTROL MEASURES MUST BE TAKEN TO PREVENT SILT FROM WASHING INTO DITCH INLET. USE RIP-RAP TO SLOW DOWN VELOCITY OF WATER & HAY BALES (OR OTHER METHODS AS APPROVED BY THE CITY) TO SETTLE OUT THE NATIVE SOILS.

DATE:  
UPDATED 1997

DRAWING NO.  
VI - 2

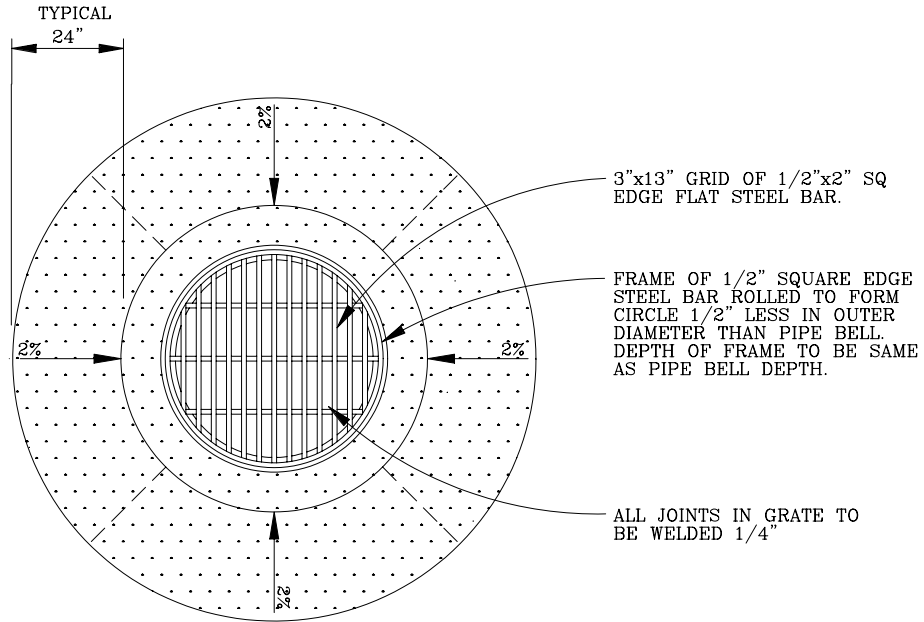

CONCRETE APRON = O.D. PIPE BELL + 24"

PLAN

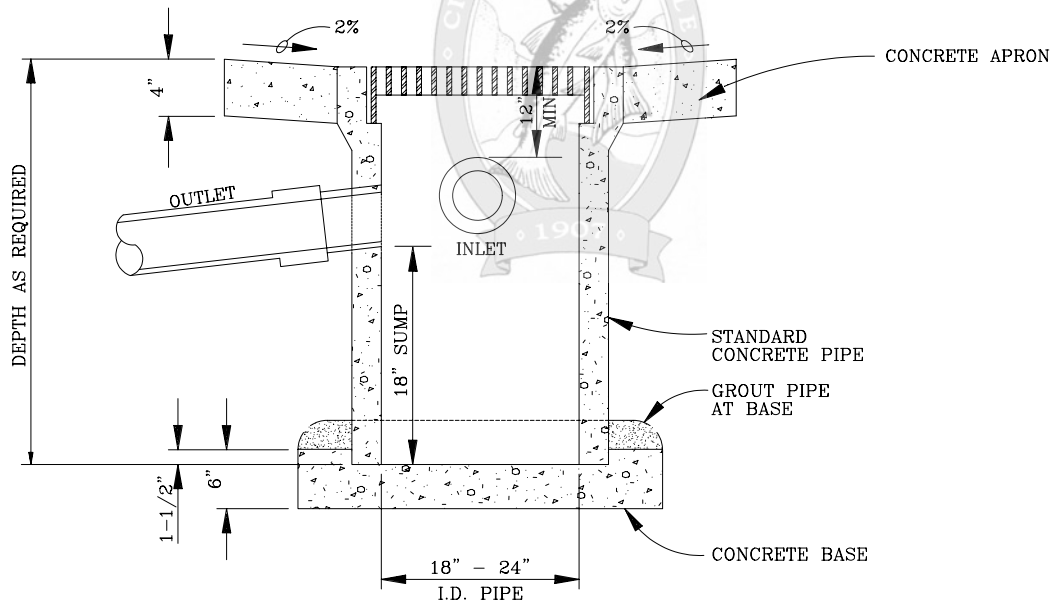

SECTION A-A

GENERAL NOTES:

1. GRATES SHALL BE CONSTRUCTED FOR BICYCLE SAFETY.
2. PRECAST CONCRETE CATCH BASINS MAY BE USED WHEN SPECIFIED OR APPROVED BY THE CITY.

CITY OF TROUTDALE

*FLAT AREA INLET*

*(IN UNIMPROVED SURFACES  
ONLY)*

DATE:

UPDATED 1997

DRAWING NO.

VI - 3

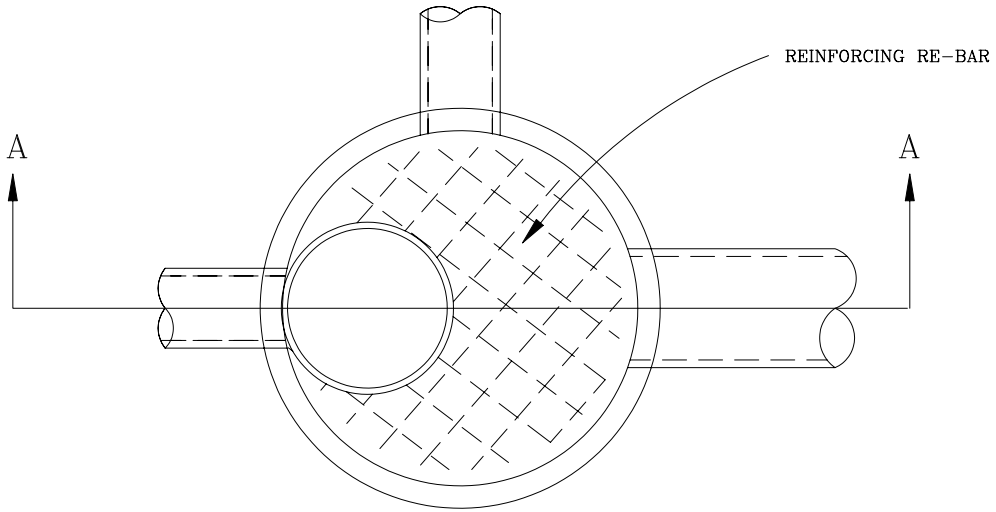

PLAN VIEW

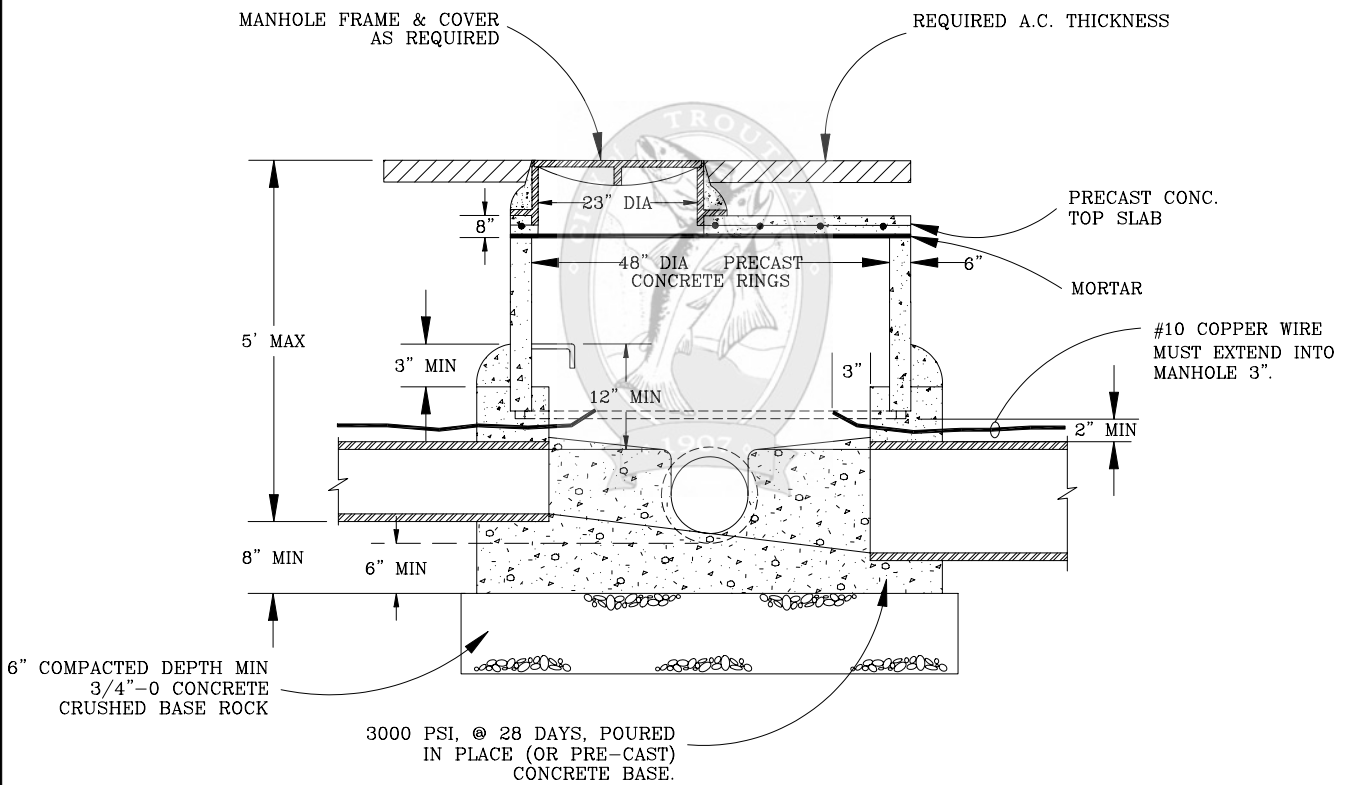

SECTION A-A

GENERAL NOTES:

1. PRECAST MANHOLE (OR POURED-IN-PLACE) BASES MAY BE USED. CHANNELS SHALL BE POURED IN PLACE.
2. FLAT TOP MANHOLES SHALL BE USED FOR STORM SEWER ONLY.
3. ALL STORM SEWER MANHOLES LOCATED ON UNPAVED ROAD SHOULDERS MUST BE ENCLOSED IN A 6'X6'X4" CONCRETE APRON (ON 2" OF CRUSHED ROCK), AROUND THE LID OF THE MANHOLE.
4. #10 COPPER TRACER WIRE INSTALLED DIRECTLY ABOVE THE MAIN MUST BE EXTENDED 3" INTO THE MANHOLE.
5. ONLY CONCRETE MANHOLES ARE ALLOWED (STORM & SANITARY)

CITY OF TROUTDALE

*FLAT TOP  
MANHOLE  
(STORM ONLY)*

DATE:  
UPDATED 1997

DRAWING NO.  
VI - 4

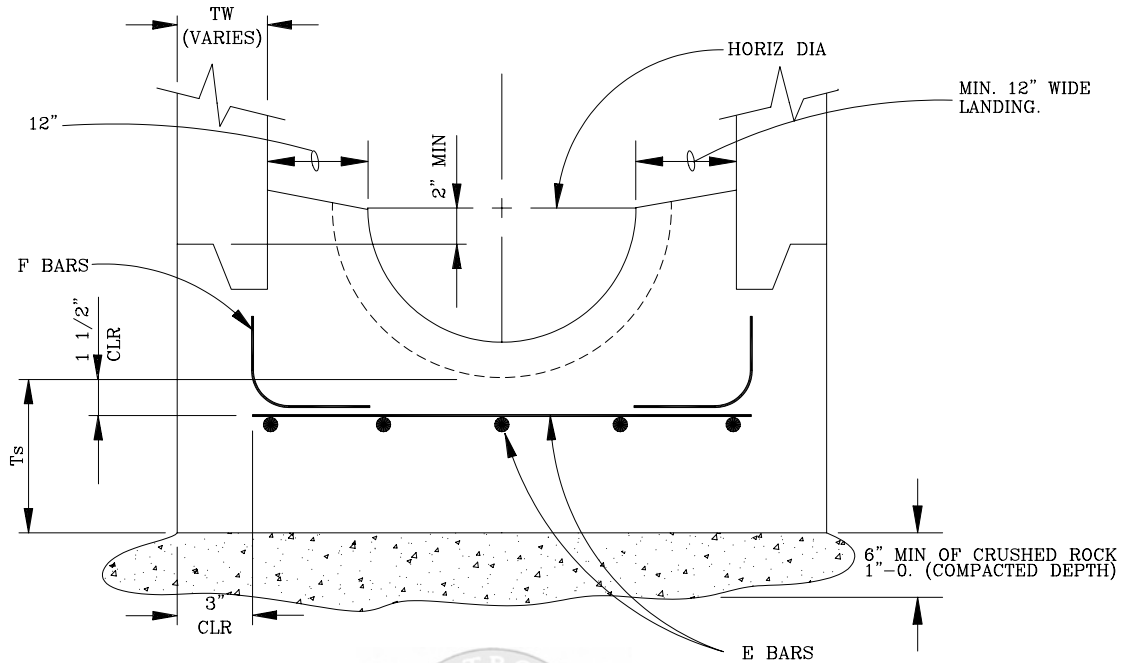

CAST-IN-PLACE BASE



| BASE I.D.     |        | 60"      |         | 72"     |         | 84"     |         | 96"     |         |
|---------------|--------|----------|---------|---------|---------|---------|---------|---------|---------|
| TYPE          | DEPTH* | 0'-15'   | 15'-30' | 0'-15'  | 15'-30' | 0'-15'  | 15'-30' | 0'-15'  | 15'-30' |
| CAST IN PLACE | Ts     | 7.0"     | 9.0"    | 7.0"    | 9.0"    | 8.0"    | 10.0"   | 9.0"    | 11.0"   |
|               | E BARS | #4 @ 12" | #4 @ 9" | #4 @ 9" | #4 @ 6" | #4 @ 8" | #5 @ 9" | #4 @ 7" | #5 @ 8" |
|               | F BARS | #4 @ 12" | #4 @ 9" | #4 @ 9" | #4 @ 6" | #4 @ 8" | #5 @ 9" | #4 @ 7" | #5 @ 8" |

\*INVERT TO STREET GRADE

GENERAL NOTES:

1. CONCRETE SHALL BE 3000 PSI, @ 28 DAYS. STEEL  $f_g$  = GRADE 60.
2. INSIDE DIAMETER OF MANHOLE MUST BE WIDE ENOUGH TO ALLOW ENOUGH ROOM FOR A 12" LANDING ON BOTH SIDES OF PIPE CHANNEL.
3. MANHOLE BASES CAN BE POURED IN PLACE OR PRE-CAST. CHANNELS SHALL BE POURED IN PLACE.
4. LARGE MANHOLE BASES SHALL BE USED FOR PIPE SIZES LARGER THAN 24 INCHES.
5. MINIMUM BASE INSIDE DIAMETER SHALL BE BASED ON THE NUMBER AND SIZE OF PIPES ENTERING MANHOLE, THE ELEVATION OF PIPES, AND MINIMUM SPACING BETWEEN PIPES. MANHOLE BASE SIZE USED SHALL BE APPROVED BY THE CITY.
6. TOP OF MANHOLE SHALL BE AT 18" ABOVE FINISH GRADE IN UNPAVED SURFACES, AND PROPERLY MARKED (SEE MARKER POST DETAIL). IF IN GRAVELED ROAD OR SHOULDER, PLACE A 6' X 6' X 4" THICK CONCRETE APRON AROUND MANHOLE.
7. STORM MANHOLES SHALL HAVE A 16-HOLE LID AND SANITARY MANHOLES A 2-HOLE LID.
8. ALL MANHOLES WILL BE VACUUM TESTED PRIOR TO ACCEPTANCE. ALL TESTS MUST BE WITNESSED BY CITY FORCES.

CITY OF TROUTDALE

LARGE CONCRETE  
STORM MANHOLE  
BASES

DATE:  
UPDATED 1997

DRAWING NO.  
VI - 5

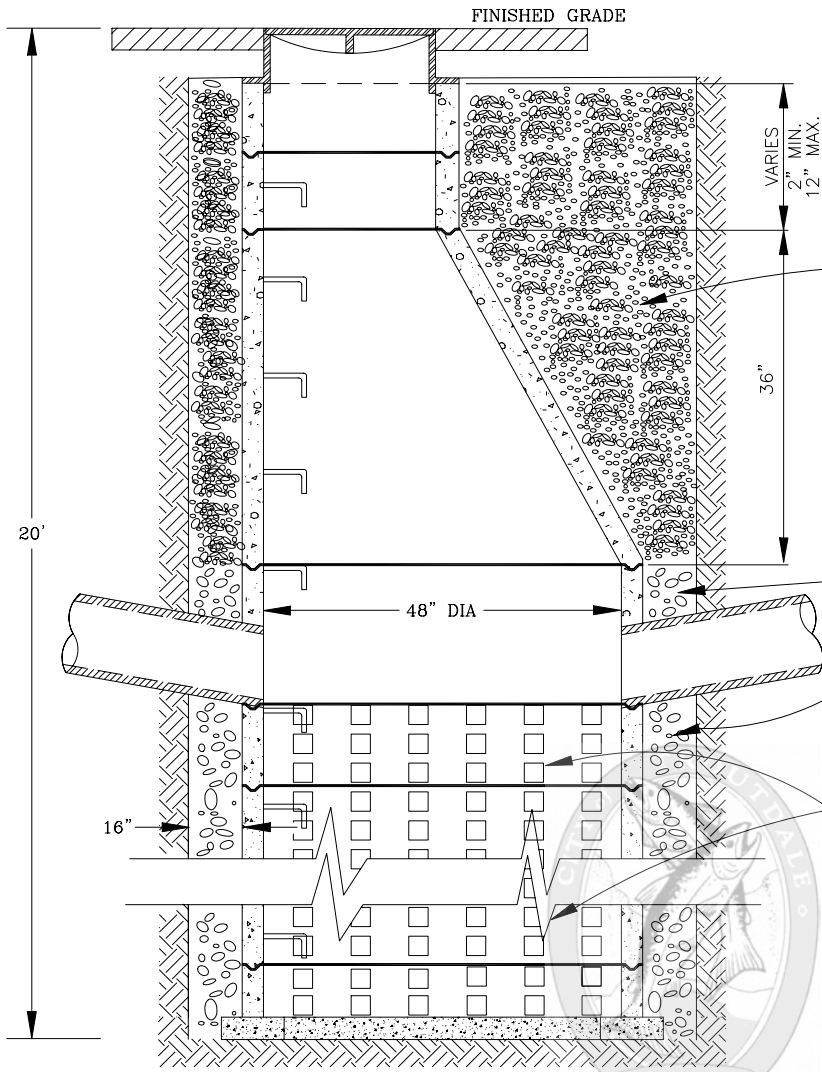

1"-0 GRANULAR BACKFILL COMPACTED IN 8" LIFTS, TO 95% OR GREATER, METHOD T-99 OR T-180. METHOD TO BE DETERMINED BY THE CITY.

DRAIN ROCK AROUND MANHOLE.

48" DIA. PERFORATED MANHOLE SECTIONS (BOTTOM OF PIPE TO BOTTOM OF DRYWELL). DRYWELL LINING IS REQUIRED, AS SHOWN BELOW.

**GENERAL NOTES:**

1. STANDARD CONCRETE MANHOLE, FRAME, COVER, CONE, AND SECTIONS, ARE REQUIRED.
2. INFILTRATION TESTS BY A QUALIFIED SOILS ENGINEER SHALL CERTIFY SOILS SUITABILITY FOR DRYWELL INSTALLATION.
3. LINE INSIDE, BOTTOM & OUTSIDE OF PERFORATED MANHOLE SECTION AS SHOWN USE MIRAFI 140.
4. FILL TO BOTTOM OF LOWEST PERFORATED MANHOLE SECTION WITH CLEAN DRAIN ROCK.
5. CONSTRUCTION OF DRYWELLS IS NOT ALLOWED WHERE STORM SEWER MAIN EXISTS NEARBY AND LOCATION(S) FALLS OUTSIDE THE LIMITS SHOWN ON DRAWING VI-10. THE CITY WILL DETERMINE WHERE DRYWELLS MAY OR MAY NOT BE CONSTRUCTED.
6. STEPS SHALL BE COATED WITH POLYPROPALINE, AND SET IN CONCRETE RINGS @ FACTORY.
7. STEPS MUST BE INSTALLED FROM 18" BELOW THE RIM OF THE DRYWELL ELEVATION TO NO MORE THAN 12" FROM THE BOTTOM OF THE DRYWELL.

## TYPICAL DRYWELL DETAIL

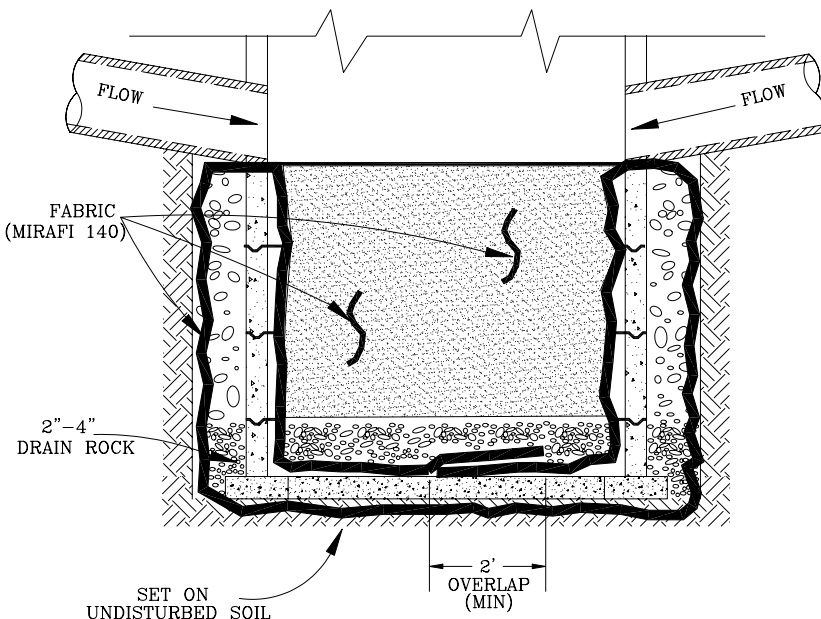

## DRYWELL LINING DETAIL

CITY OF TROUTDALE

# DRYWELL DETAIL

DATE:  
UPDATED 1997

DRAWING NO.  
VI - 6

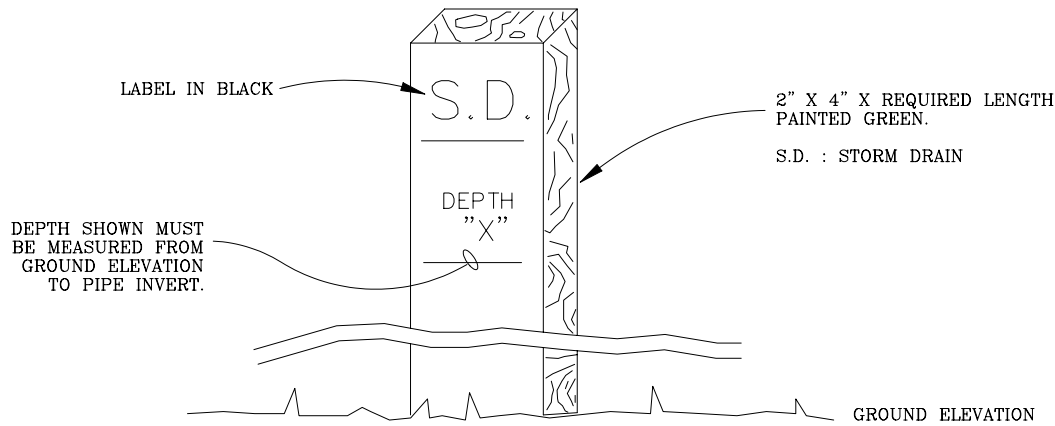

**2x4 MARKER LABELS**

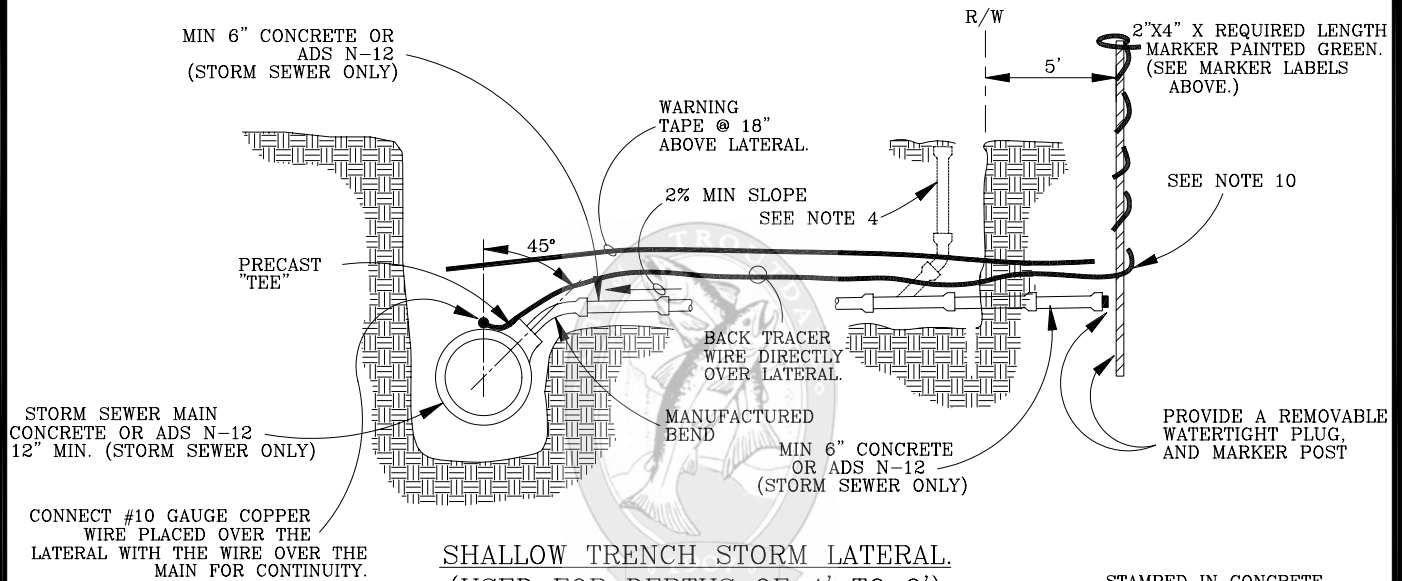

**SHALLOW TRENCH STORM LATERAL  
(USED FOR DEPTHS OF 4' TO 9')**

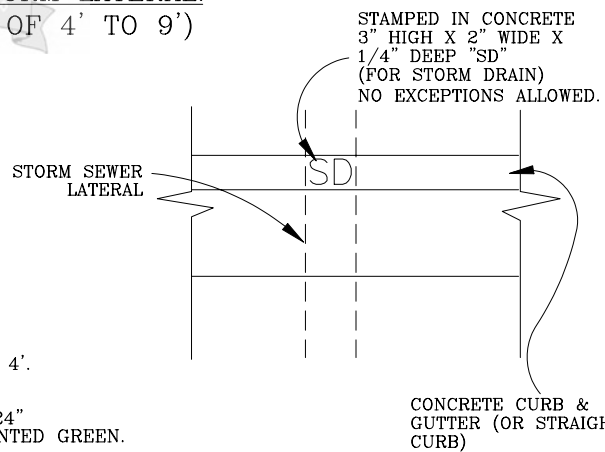

**GENERAL NOTES:**

1. PIPE AND FITTINGS SHALL BE COMPATIBLE.
2. MINIMUM DEPTH AT RIGHT-OF-WAY OR EASEMENT LINE SHALL BE 4'.
3. MARKER POSTS SHALL BE TREATED WOOD. POST SHALL BE 2" x 4" X REQUIRED LENGTH, FIR. POST TO EXTEND 24" MINIMUM ABOVE FINISH GRADE AND EXPOSED AREA SHALL BE PAINTED GREEN.
4. WHEN REQUIRED, A CLEANOUT SHALL BE INSTALLED @ 100' INTERVALS.
5. MARK ALL STORM LATERALS WITH A GREEN "SD" (FOR STORM DRAIN) ON FACE OF CURB WHERE LATERAL CROSSES CURB.
6. IN ADDITION TO NOTE #5 ABOVE, STAMP (IN CONCRETE) A 3" HIGH BY 2" WIDE BY 1/4" DEEP "SD" (FOR STORM DRAIN) ON TOP OF THE CONCRETE CURB FOR FUTURE LOCATES.
7. LATERAL SHALL NOT BE BACKFILLED PRIOR TO INSPECTION BY CITY FORCES.
8. VERTICAL DROPS INTO STORM MAIN ARE NOT PERMITTED.
9. FLAT "T'S" MUST BE APPROVED BY THE CITY.
10. INSTALL #10 TRACER COPPER WIRE DIRECTLY OVER LATERAL & RAP AROUND 2" X 4" MARKER AS SHOWN. TRACER TAPE MUST ALSO BE INSTALLED 18" ABOVE THE PIPE.
11. A "CONTINUITY TEST" OF THE #10 GAUGE TRACER WIRE IS REQUIRED.

CITY OF TROUTDALE

**STORM SEWER LATERAL  
AND MARKER  
(SHALLOW TRENCH)**

DATE:  
UPDATED 1997

DRAWING NO.  
VI - 7

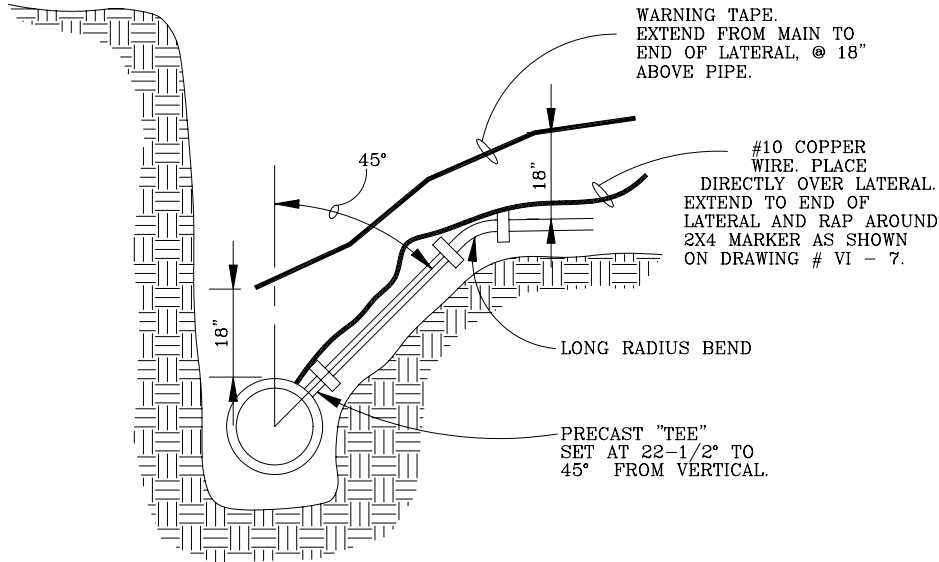

**45° TAP TO MAIN**  
(USED FOR DEPTHS OF 10' TO 14')

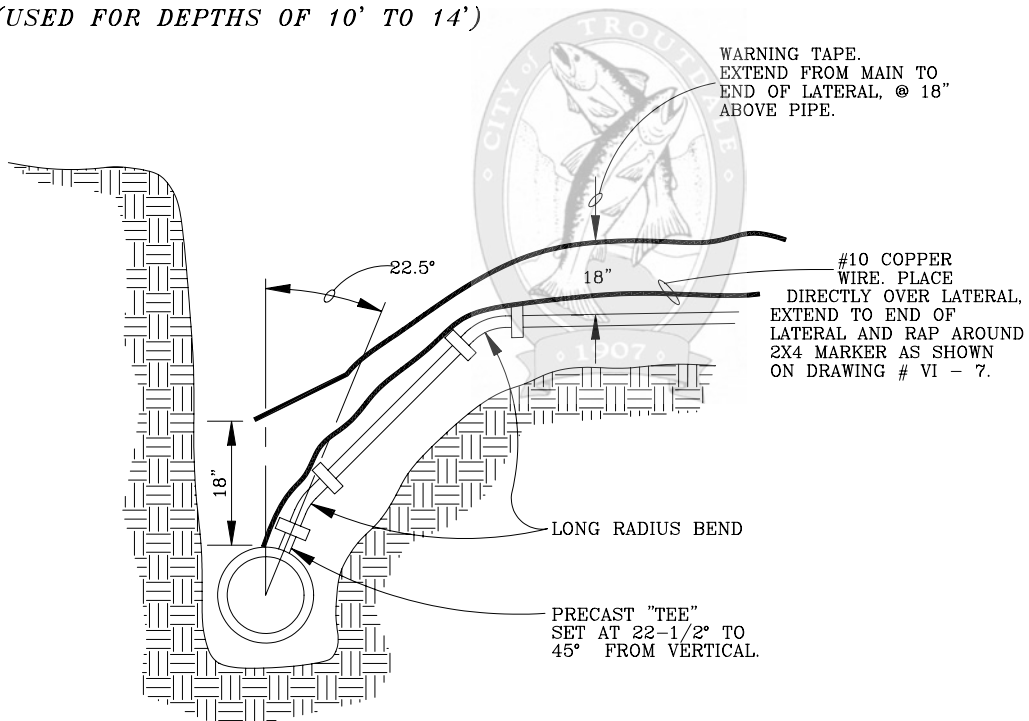

**22.5° TAP TO MAIN**  
(USED FOR EXTREME DEPTHS OF 15' OR >)

**GENERAL NOTES:**

1. PIPE AND FITTINGS SHALL BE COMPATIBLE.
2. MINIMUM DEPTH AT RIGHT-OF-WAY OR EASEMENT LINE SHALL BE 4'
3. PLUGGING, AND MARKING OF UNCONNECTED SERVICES SHALL CONFORM TO DRAWING # VI - 7, STORM SEWER LATERAL AND MARKER (SHALLOW TRENCH).
4. SEE ADDITIONAL NOTES ON DRAWING VI - 7 (SHALLOW TRENCH SERVICE) FOR DETAILS ON LATERAL MARKINGS AND OTHER GENERAL REQUIRMENTS.

CITY OF TROUTDALE

**STORM SEWER  
LATERAL  
(DEEP TRENCH)**

DATE:

UPDATED 1997

DRAWING NO.

VI - 8

MANHOLE FRAME AND COVER  
AS SPECIFIED IN DRAWING VIII - 2.

FRAME AND RISER RINGS  
SHALL BE SEALED WITH  
GROUT. (STORM ONLY)

PRECAST RISER RINGS

PROVIDE TYPICAL  
MANHOLE STEPS  
@ 12" O/C FOR STORM  
MANHOLES DEEPER THAN 24"

ALL JOINTS SHALL BE  
SEALED WITH GROUT

STANDARD CONCRETE PRECAST  
MANHOLE SECTIONS  
AS REQUIRED.

#10 COPPER WIRE OVER  
THE STORM SEWER MAIN IS  
TO EXTEND INTO THE MANHOLE  
3". NO EXCEPTIONS ALLOWED.

3000 PSI @ 28 DAYS  
CONCRETE MANHOLE BASE

6" MIN. COMPACTED DEPTH  
OF 3/4"-0 CRUSHED  
BASE ROCK.

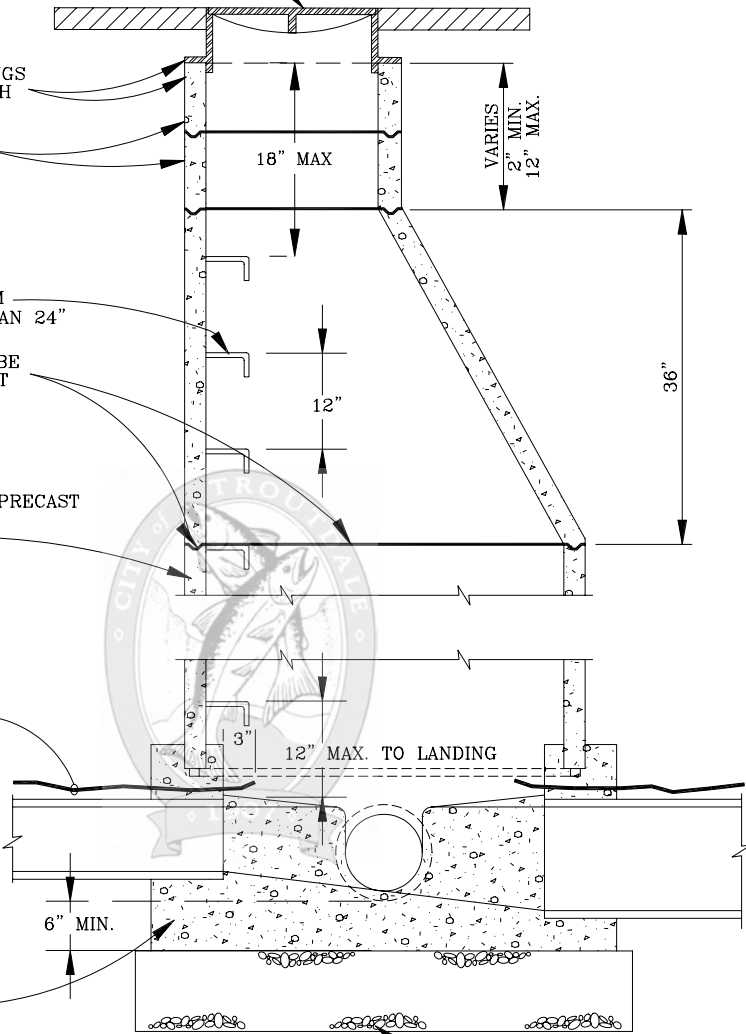

GENERAL NOTES:

1. STANDARD PRECAST CONCRETE MANHOLE SECTION DIAMETER SHALL BE 48", UNLESS OVERSIZED PIPE IS BEING USED.
2. PRECAST OR POURED IN PLACE CONCRETE MANHOLE BASES ARE ALLOWED. CHANNELS MUST BE POURED IN PLACE.
3. MANHOLES (STORM OR SANITARY) MADE OF PLASTIC AND/OR FIBER-GLASS ARE NOT ALLOWED.
4. STEPS WILL BE STEEL COATED WITH POLYPROPALINE WITH REFLECTORS.
5. PROVIDE STEPS FOR ALL MANHOLES DEEPER THAN 24".
6. TOP OF MANHOLES SHALL BE @ 18" ABOVE EXISTING GROUND IN UNPAVED SURFACES, AND PROPERLY MARKED (SEE MARKER POST DETAIL DRAWING # VIII - 8). TOP OF MANHOLE SHOULD BE FLUSH WITH TOP OF FINISH GRADE IN PAVED AREAS. IF IN GRAVEL ROAD OR SHOULDER, PLACE A 6' DIAMETER 4" THICK CONCRETE APRON AROUND MANHOLE. SLOPE APRON AWAY FROM MANHOLE @ 1/4"/FT.
7. A MINIMUM OF 0.2' DROP MUST BE PROVIDED @ ALL MANHOLES FROM INLET PIPE TO OUTLET PIPE.
8. CONSTRUCTION OF MANHOLES IN UNACCESSIBLE AREAS IS NOT ALLOWED. ALL MANHOLES MUST BE ACCESSIBLE AT ALL TIMES BY THE CITY MAINTENANCE PERSONNEL AND EQUIPMENT.

CITY OF TROUTDALE

*STORM  
MANHOLE  
(48" DIAMETER)*

DATE:

UPDATED 1997

DRAWING NO.

VI - 9

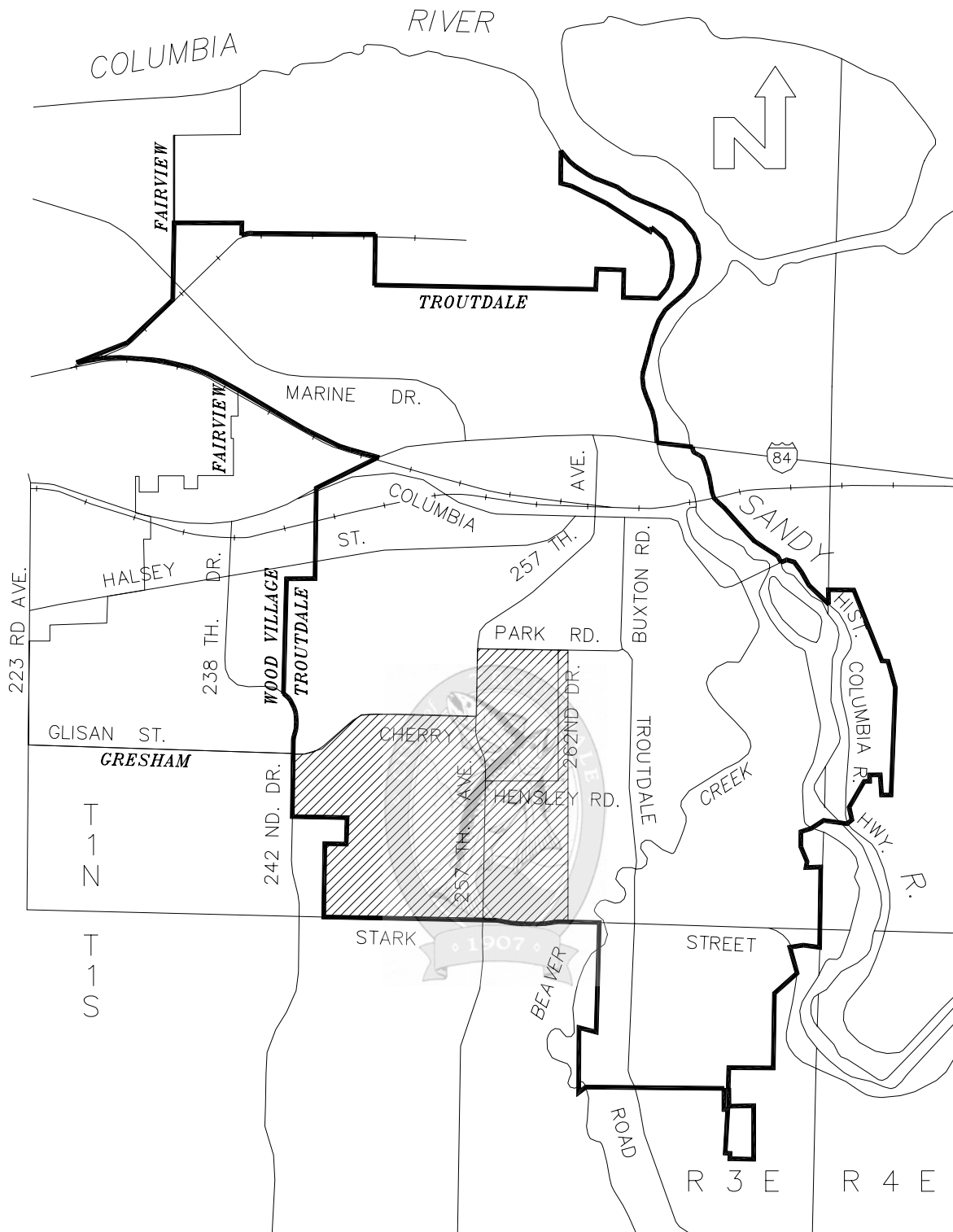

GENERAL NOTES:



DRYWELLS PERMITTED IN THIS AREA IF A GEOTECHNICAL ENGINEER, REGISTERED IN THE STATE OF OREGON, VERIFIES/CERTIFIES SUITABILITY. DRYWELLS IN OTHER AREAS NOT HATCHED ABOVE ARE NOT ALLOWED.

CITY OF TROUTDALE

*PERMITTED  
DRYWELL AREA*

DATE:

JANUARY 1997

DRAWING NO.

VI-10