

# **SANITARY SEWER COLLECTION SYSTEM**



**(Part VII & VIII)**

# **SANITARY**



**(Part VII)**

**\*General Requirements**

## **SANITARY SEWERS**

### **(General Requirements)**

- 1. Proposed sanitary sewer mains must be in accordance with the City of Troutdale's Public Facilities Plan. Sanitary main sizes must be adequately sized to handle the flow collected from the affected development. Areas above and below the development must be considered in design, and pipes sized accordingly.**
- 2. All construction/installation of sanitary sewer mains shall be done in a safe, neat and professional manner, and under supervision of City forces at all times. All safety requirements from OSHA and other state regulatory agencies must be met.**
- 3. All requirements of the DEQ must be met. As required by OAR 340-52-015, all construction plans of public improvements involving the construction of new sanitary lines must be sent to the DEQ for their review and approval. This will be done by the City upon submittal of accepted drawings and the required fee by the developer. DEQ approval must be sent to the City before an authorization to begin construction can be granted.**
- 4. Manholes shall be placed at all points of change in alignment, change in pipe size, breaks in grade and at all intersections. The maximum permissible spacing is 300 feet. Sanitary sewer manholes shall not be located in backyards or any other areas which would restrict free access to manholes by maintenance personnel and vehicles.**
- 5. The minimum size for public sewer mains shall be eight-inch diameter. All sanitary sewer piping shall be schedule D3034 PVC or equal. Minimum pipe diameter for private laterals is 4" and of schedule D3034 PVC or equal. All sanitary sewer laterals must be properly marked at ends as shown on Drawing VIII-9. Use of "concrete" and ADS N-12 pipe for sanitary sewer mains and laterals is not allowed.**
- 6. All manholes shall have a minimum of 0.2 foot drop from pipe invert "in" to pipe invert "out", and all sanitary lines between manholes shall meet the minimum allowable slope requirements as required by general engineering principles and DEQ's rules and regulations.**
- 7. Sewer lines shall be laid in a straight alignment and in a uniform grade between the manholes.**
- 8. Sewer depth shall be adequate to serve all property(s) which may be contributory, but no shallower than 6 feet from finished street grade.**
- 9. Combined storm and sanitary sewers are strictly prohibited.**

10. Vertical drops will be required for vertical drops exceeding 24 inches. Drops should be avoided whenever possible. All inside drops must be reviewed and approved by the City prior to construction.
11. Connections into the existing sanitary sewer mains require issuance of a public works permit and inspection by the City prior to backfilling. A permit fee of \$50.00 will be assessed for each connection/inspection.
12. All new sanitary sewer pipes and manholes must be thoroughly cleaned, video taped and pressure/vacuum tested as required by the DEQ and the City. All tests must be witnessed and passed by the City prior to placing into operation.
13. All drains from private/public swimming pools must be connected to the sanitary sewer and not to the storm sewer. All other privately owned facilities high in chlorine content or any other strong chemical mixture shall be connected to the sanitary sewer only. Approval from the City is required when making such connections to the sanitary main. Pretreatment regulations may apply; the City will determine this on a per-project basis.
14. There shall only be one sanitary sewer lateral connection per residential dwelling. Also, added discharge points in laterals for discharge or use by recreation vehicles, et cetera, is strictly prohibited.
15. All public sanitary sewer mains extending into, under, above, through, and beyond private property, shall be placed within a legal public utility easement granted to the City by the affected property owner prior to actual construction. Width and length of such easement will be determined by the City, and will be based on size, type, depth and length of pipe being used. All Building Code restrictions, as they apply to public utility easements, shall apply.
16. Public sanitary sewer lines within streets will only be installed in public rights-of-way. Any sanitary sewer line installed within private streets will be privately owned and maintained. Public responsibility for the sanitary sewer collection system stops at the sewer main and does not include laterals to individual properties.
17. The builder/developer must provide to the City any guarantee or warranty normally furnished with the purchase of any materials used in connection with the project at hand. In addition, they must furnish the City a written warranty providing satisfactory in-service operation of all work performed by affected contractor (including but not limited to all sanitary mains, laterals, manholes, pump stations, force mains, etc.) for a period of two (2) years following date of project acceptance.
18. All other construction practices (relating to sanitary sewer) within the City's public right-of-way, not covered in these "General Requirements" and/or "Construction

Details" sections, shall comply with the rules and regulations found in the most recent edition of the "American Public Works Association Standard Specifications".

19. All new improvements proposed for construction and intended for public dedication (once these facilities are constructed to City standards) must be proposed to the City in writing, by the developer and/or legal owner of the project, prior to the receipt of an authorization to begin construction from the City. This formal written request from the developer/owner to the City must be reviewed and approved by the City, and then signed by both parties to formally bind both parties to the agreement.



# **SANITARY**



**(Part VIII)**

**\* Construction Details**

MANHOLE FRAME AND COVER  
AS SPECIFIED IN DRAWING VIII - 2.

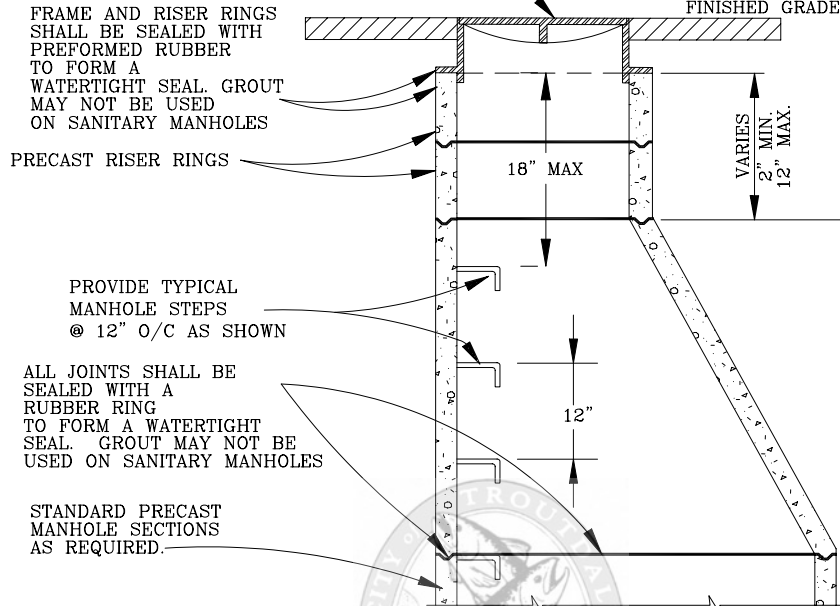

FRAME AND RISER RINGS  
SHALL BE SEALED WITH  
PREFORMED RUBBER  
TO FORM A  
WATERTIGHT SEAL. GROUT  
MAY NOT BE USED  
ON SANITARY MANHOLES

PRECAST RISER RINGS

PROVIDE TYPICAL  
MANHOLE STEPS  
@ 12" O/C AS SHOWN

ALL JOINTS SHALL BE  
SEALED WITH A  
RUBBER RING  
TO FORM A WATERTIGHT  
SEAL. GROUT MAY NOT BE  
USED ON SANITARY MANHOLES

STANDARD PRECAST  
MANHOLE SECTIONS  
AS REQUIRED.

#10 COPPER WIRE  
OVER THE SANITARY  
SEWER MUST EXTEND  
3" INTO THE  
MANHOLE AS SHOWN.

3000 PSI @ 28 DAYS  
CONCRETE MANHOLE BASE

**GENERAL NOTES:**

1. STANDARD CONCRETE PRECAST MANHOLE SECTION DIAMETER SHALL BE 48".
2. MANHOLE BASES MAY BE CONCRETE PRECAST OR POURED IN PLACE. CHANNELS SHALL BE POURED IN PLACE.
3. MANHOLES (SANITARY OR STORM) MADE OF PLASTIC AND/OR FIBERGLASS ARE NOT ALLOWED.
4. STEPS WILL BE STEEL COATED WITH POLYPROPALINE WITH REFLECTORS.
5. PROVIDE STEPS FOR ALL MANHOLES DEEPER THAN 24".
6. TOP OF MANHOLES SHALL BE @ 18" ABOVE EXISTING GROUND IN UNPAVED SURFACES, AND PROPERLY MARKED (SEE MARKER POST DETAIL DRAWING # VIII - 8). TOP OF MANHOLE SHOULD BE FLUSH WITH TOP OF FINISH GRADE IN PAVED AREAS.
7. A MINIMUM OF 0.2' DROP MUST BE PROVIDED @ ALL MANHOLES FROM INLET PIPE TO OUTLET PIPE.
8. ALL MANHOLES SHALL BE VACUUM TESTED AND PASSED PRIOR TO ACCEPTANCE BY THE CITY.
9. MANHOLES LOCATED ON ROAD SHOULDER(S) NOT PAVED MUST BE ENCLOSED IN A 6'X6'X4" CONCRETE APRON ON 2" OF CRUSHED ROCK. SLOPE APRON AWAY FROM MANHOLE @ 1/4"/FT.
10. DO NOT CONSTRUCT SANITARY SEWER MANHOLES WITHIN THE CURB & GUTTER AREA; OR, IN ANY OTHER DIRECT DRAINAGE WAY.

6" MIN. COMPACTED DEPTH  
OF 3/4"-0 CRUSHED  
BASE ROCK.

CITY OF TROUTDALE

**SANITARY  
MANHOLE  
(48" DIAMETER)**

DATE:  
UPDATED 1997

DRAWING NO.  
VIII - 1

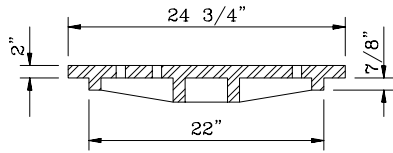
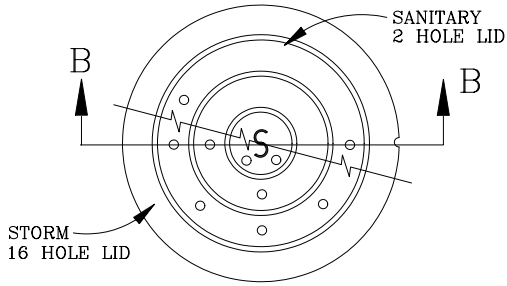

SECTION B-B

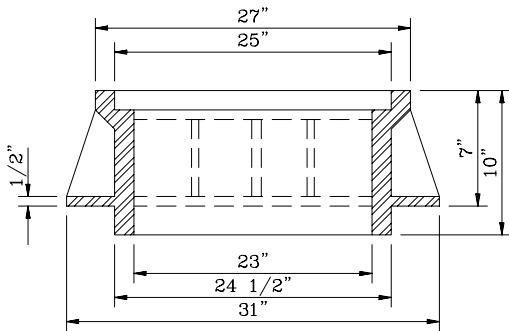

(APPROX. WT. - 387 LBS.)  
CAST IRON STANDARD

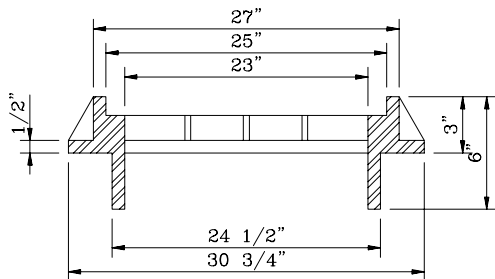

(APPROX. WT. - 305 LBS.)  
CAST IRON SUBURBAN

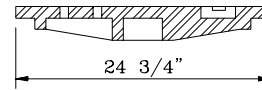
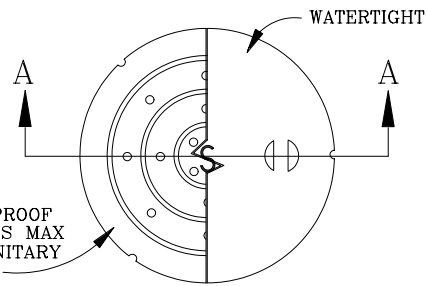

SECTION A-A

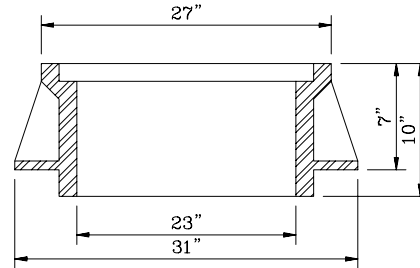

CAST IRON TAMPERPROOF & WATERTIGHT

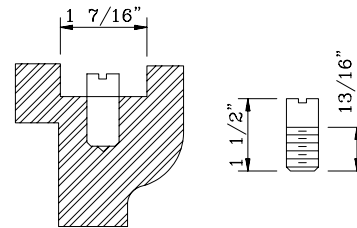

1 REQUIRED PER COVER FOR  
WATERTIGHT AND TAMPERPROOF  
LOCATING STUD DETAILS

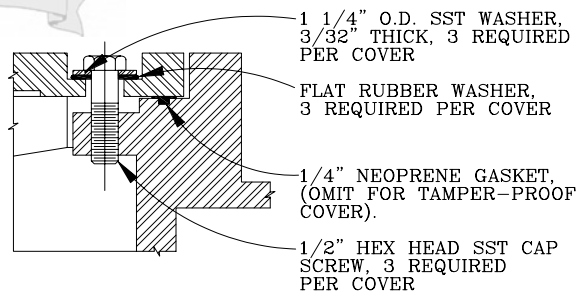

- 1 1/4" O.D. SST WASHER, 3/32" THICK, 3 REQUIRED PER COVER
- FLAT RUBBER WASHER, 3 REQUIRED PER COVER
- 1/4" NEOPRENE GASKET, (OMIT FOR TAMPER-PROOF COVER).
- 1/2" HEX HEAD SST CAP SCREW, 3 REQUIRED PER COVER

NOTE:  
3 REQUIRED, 1/2" x 1 1/4" PENTAGONAL OR HEXAGONAL HEAD, BRONZE OR CAD. PLATED.

BOLT-DOWN DETAIL  
(FOR TAMPERPROOF AND WATERTIGHT)

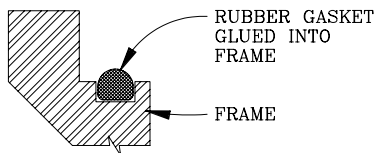

WATERTIGHT GASKET DETAIL

GENERAL NOTES:

1. TAMPERPROOF COVERS REQ'D ON SANITARY OR STORM DRAIN MANHOLE WHERE LOCATED IN PEDESTRIAN WAYS OR EASEMENT AREAS. TAMPERPROOF COVERS FOR SANITARY MANHOLES SHALL HAVE 2 HOLES MAXIMUM.
2. WATERTIGHT COVERS ARE REQUIRED IF LOCATED WHERE COVER MAY BE SUBMERGED, OR IN CURB/GUTTER LINE.
3. USE CAST IRON STANDARD UNLESS OTHERWISE REQUIRED BY THE CITY.

CITY OF TROUTDALE

MANHOLE LIDS  
AND FRAMES  
(SANITARY AND STORM)

DATE:  
UPDATED 1997

DRAWING NO.  
VIII - 2

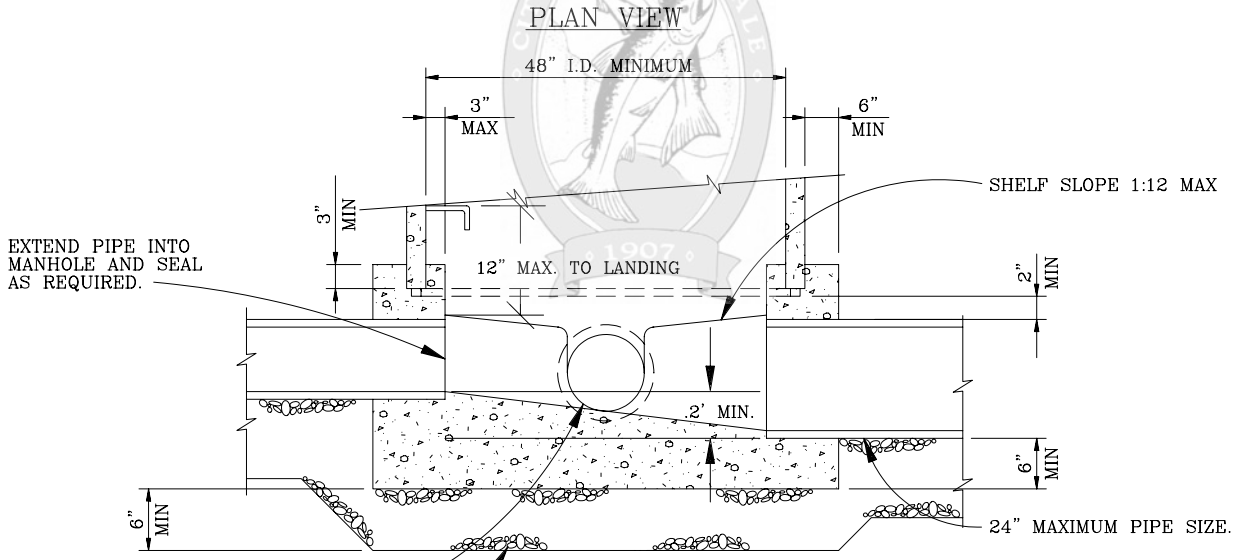
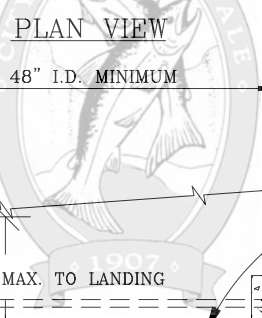
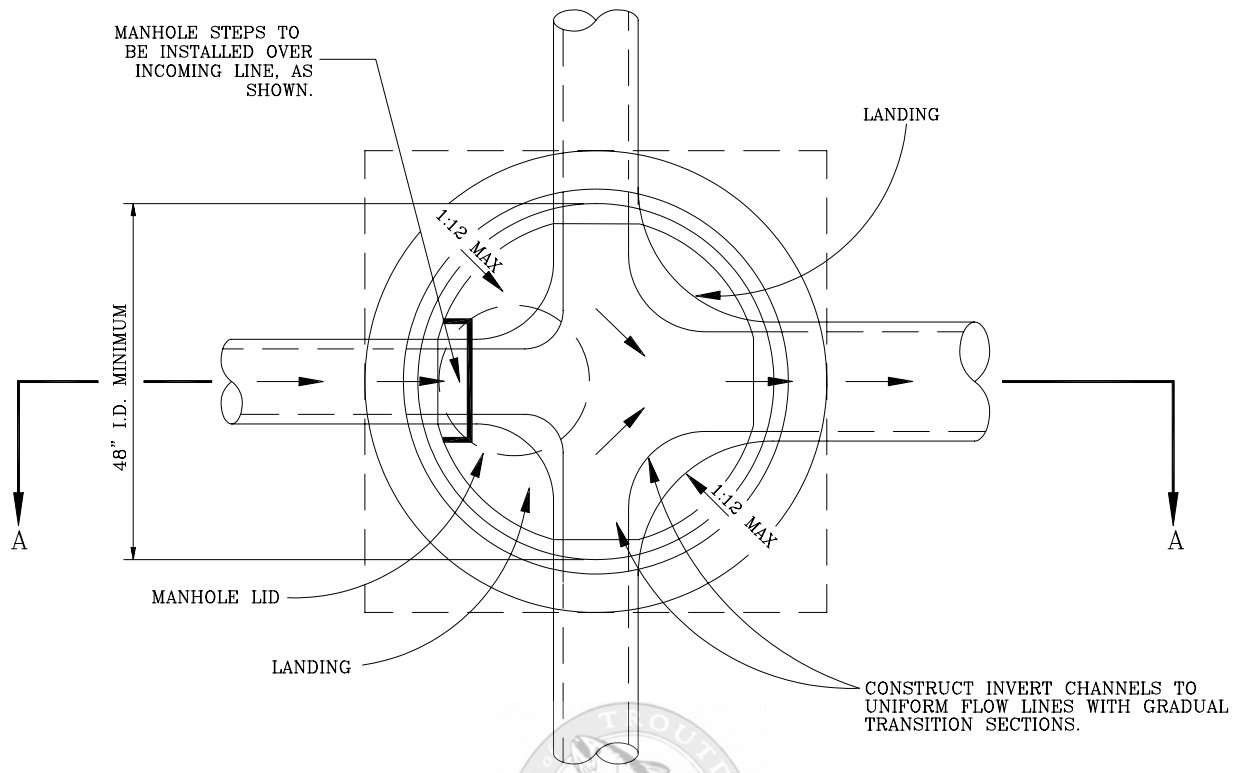

SHAPE CHANNEL TO MATCH BOTTOM HALF OF PIPE.

COMPACTED 3/4"-0 CRUSHED AGGREGATE BASE (6" MINIMUM)

SECTION A-A

**GENERAL NOTES:**

1. CHANNELS SHALL BE CONSTRUCTED TO PROVIDE SMOOTH SLOPES AND RADII TO OUTLET PIPE. AND, ALL CHANNEL INTERSECTIONS IN MANHOLES SHALL BE FORMED IN A MANNER THAT PROMOTES UNRESTRICTED FLOW OF SEWAGE FROM ALL CHANNELS, AND WITH NO SWIRLING/OR BACKUP OF WASTE WATER IN ANY CHANNEL.
2. BASES MAY BE POURED IN PLACE OR PRECAST. USE 3000 PSI CONCRETE @ 28 DAYS FOR BASE IF POURED IN PLACE.
3. ALLOW A MINIMUM OF 24 HOURS TO ELAPSE BEFORE PLACING REMAINING RINGS AND CONE.
4. THIS MANHOLE BASE SECTION SHALL BE USED FOR PIPE SIZES UP TO 24" ONLY. A LARGER SIZE BASE IS REQUIRED IF LARGER PIPE SIZE IS NECESSARY.
5. A MINIMUM OF 0.2' DROP IS REQUIRED FROM INLET PIPE TO OUTLET PIPE.

CITY OF TROUTDALE	
<b>48" MANHOLE BASE (SANITARY OR STORM)</b>	
DATE: UPDATED 1997	DRAWING NO. VIII - 3

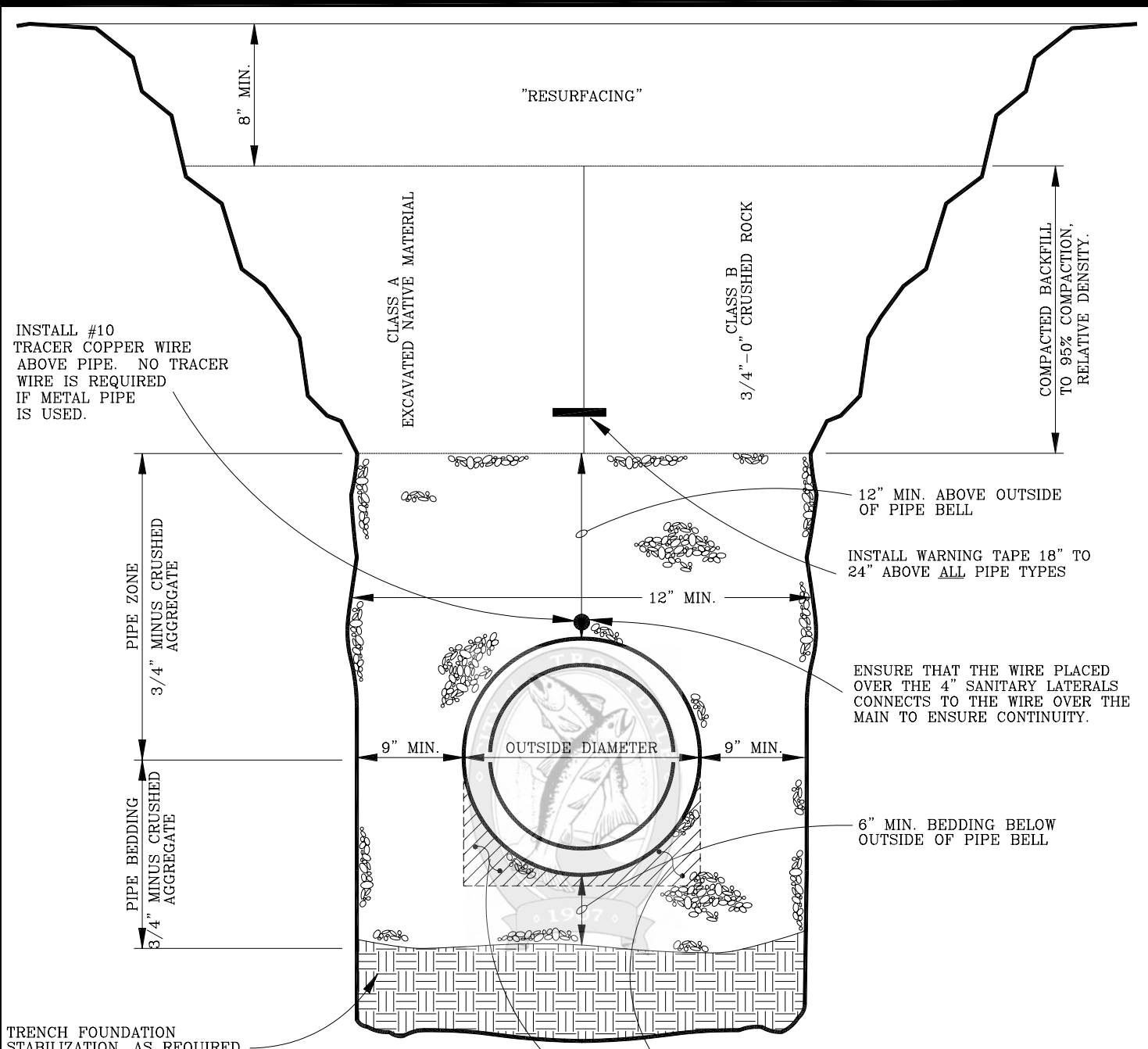

INSTALL #10 TRACER COPPER WIRE ABOVE PIPE. NO TRACER WIRE IS REQUIRED IF METAL PIPE IS USED.

TRENCH FOUNDATION STABILIZATION, AS REQUIRED

**GENERAL NOTES:**

1. THIS TRENCH/PIPE DETAIL APPLIES FOR INSTALLATION OF PLASTIC, PVC, DUCTILE IRON, CAST IRON AND CONCRETE PIPES.
2. WARNING TAPE AND COPPER WIRE #10 ARE REQUIRED FOR ALL PLASTIC, PVC, AND CONCRETE PIPES. COPPER WIRE IS NOT REQUIRED OVER DUCTILE OR CAST IRON PIPES; HOWEVER, TRACER TAPE IS, AS SHOWN ABOVE.
3. ALL PLASTIC OR PVC PIPES WILL BE TESTED FOR "ROUNDNESS" AFTER COMPACTION BY RUNNING A MANDRELL (OR OTHER METHOD AS REQUIRED BY THE CITY) THROUGH ALL PIPES.
4. ALL PIPES SHALL BE CHLORINATED, PRESSURE TESTED, FLUSHED AND OTHERWISE TESTED AS REQUIRED BY THE CITY. METHODS REQUIRED TO TEST PIPES WILL DEPEND ON INTENDED USE OF PIPE. ALL TESTS MUST BE WITNESSED BY CITY FORCES. METHODS FOR TESTING AND ACCEPTABLE RESULTS USED WILL BE AS SPECIFIED IN THE LATEST EDITION OF THE APWA STANDARD SPECIFICATIONS.
5. TYPE OF BACKFILL USED WILL BE DETERMINED BY THE CITY
6. BEDDING GREATER THAN 6" IN DEPTH MAY BE REQUIRED BY THE CITY, IF NATIVE MATERIAL IS NOT SUITABLE.
7. ALL CURRENT SAFETY REQUIREMENTS OR REGULATIONS (AS SET FORTH BY OSHA AND OTHER STATE REGULATORY AGENCIES) MUST BE ADHERED TO DURING TRENCH EXCAVATION.
8. WHEN DIGGING TRENCH IN TRAFFIC ZONES, A TRAFFIC PLAN MUST BE APPROVED BY THE CITY OF TROUTDALE OR AFFECTED JURISDICTION.

- ENSURE THAT BEDDING MATERIAL IS CAREFULLY PLACED (HAUNCHED) IN SHADED AREA, TO PREVENT "EGG-SHAPING" SOFT PIPES DURING COMPACTION. (NO EXCEPTIONS ALLOWED)
9. AN "ELECTRICAL CONTINUITY" TEST OF ALL TRACER WIRE OVER MAINS/LATERALS IS REQUIRED UPON COMPLETION.

CITY OF TROUTDALE

**TRENCH BACKFILL  
BEDDING  
AND PIPE ZONE**

DATE: UPDATED 1997	DRAWING NO. VIII - 4
-----------------------	-------------------------

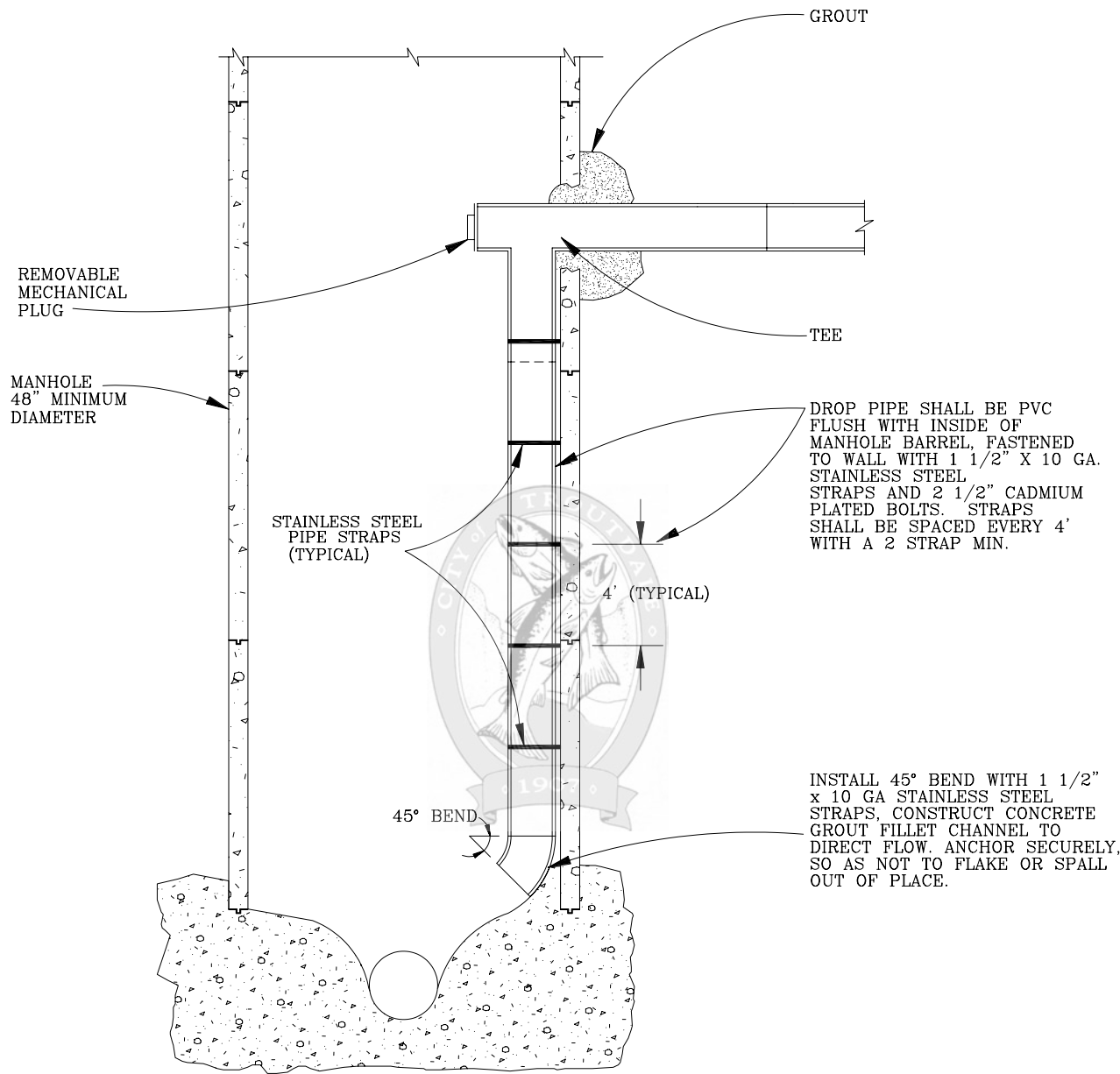

GENERAL NOTES:

1. ONLY ONE INSIDE DROP CONNECTION WILL BE ALLOWED PER MANHOLE.
2. DROP MANHOLE CONFIGURATION (AS SHOWN) IS REQUIRED IF PIPE IS 25" OR HIGHER FROM LANDING (AT BOTTOM OF MANHOLE) TO PIPE INVERT.
3. APPROVAL IS REQUIRED BY CITY FOR "ALL" DROP CONNECTIONS.
4. CITY MAY REQUIRE THAT AN "OUTSIDE DROP CONNECTION" BE PROVIDED-SEE DRAWING # VIII - 6.

CITY OF TROUTDALE

***INSIDE DROP CONNECTION FOR MANHOLES (SANITARY OR STORM)***

DATE:  
UPDATED 1997

DRAWING NO.  
VIII - 5

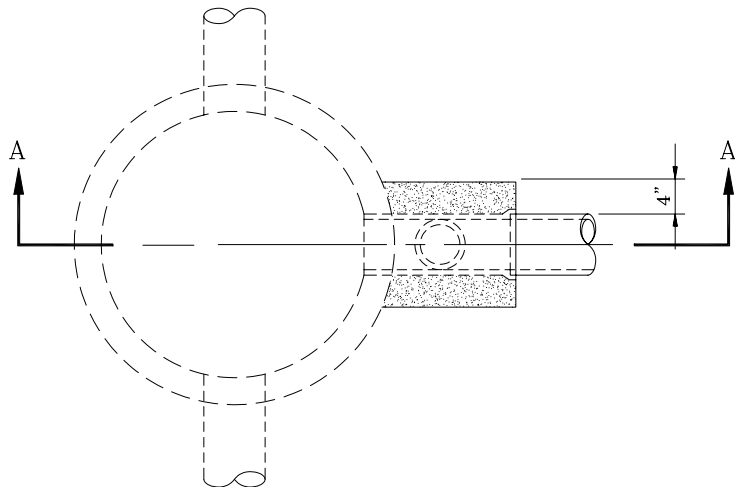

PLAN VIEW

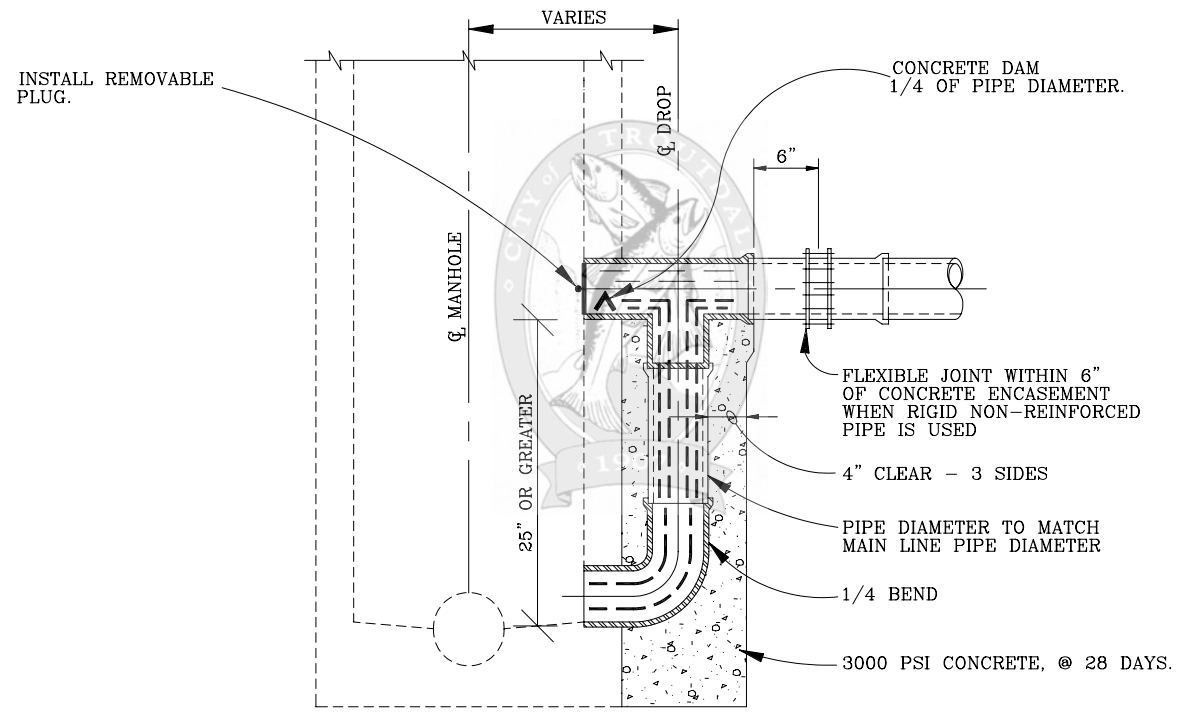

SECTION A-A

GENERAL NOTES:

1. DROP MANHOLE CONFIGURATION (AS SHOWN) IS REQUIRED IF PIPE IS HIGHER THAN 25" FROM LANDING (@ BOTTOM OF MANHOLE) TO PIPE INVERT.
2. APPROVAL IS REQUIRED BY CITY FOR ALL DROP CONNECTIONS.
3. CITY MAY REQUIRE THAT AN "INSIDE DROP CONNECTION" BE PROVIDED. SEE DRAWING # VIII - 5.

CITY OF TROUTDALE	
<b><i>OUTSIDE DROP CONNECTION FOR MANHOLES (SANITARY OR STORM)</i></b>	
DATE: UPDATED 1997	DRAWING NO. VIII - 6



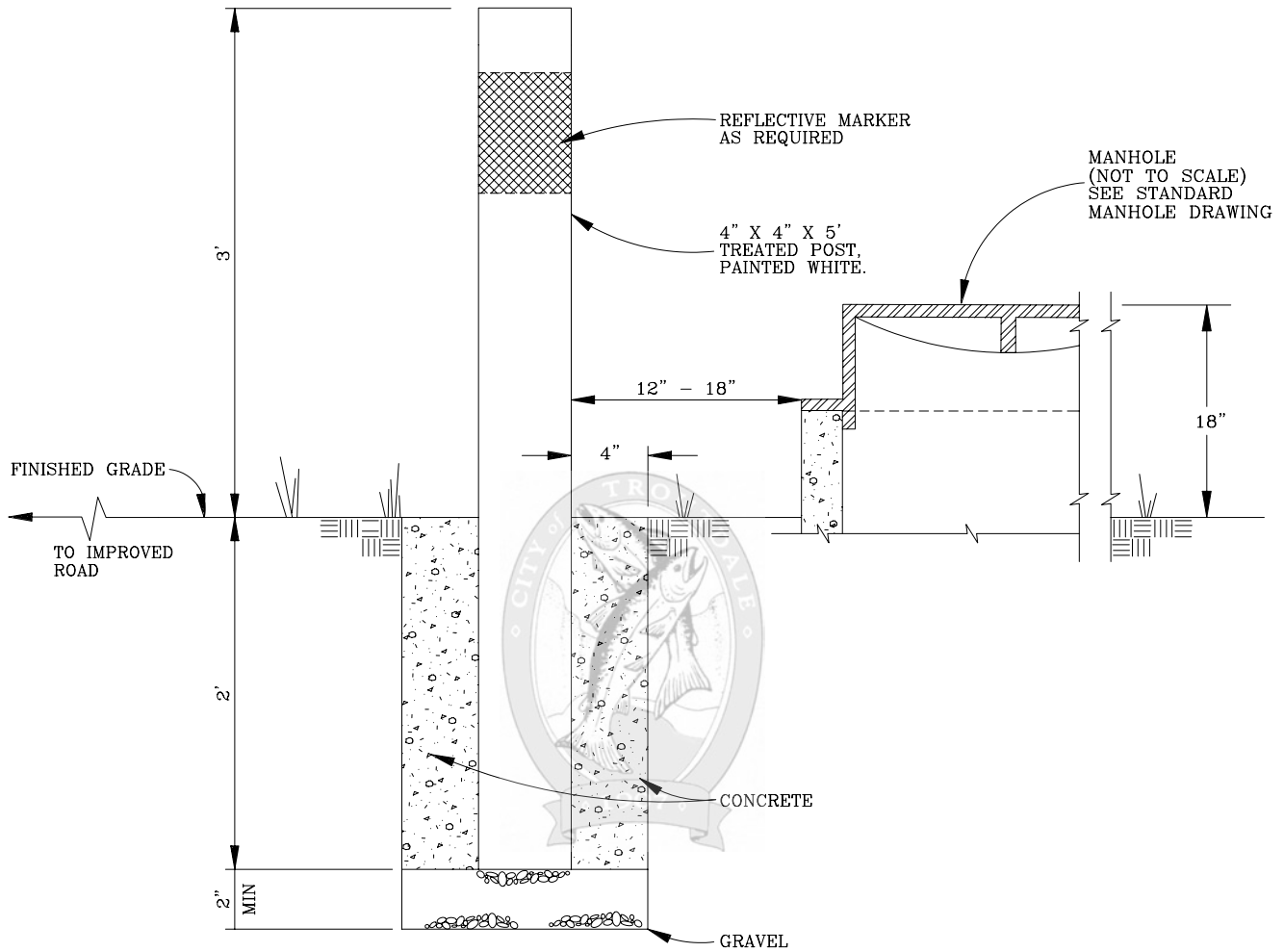

MARKER POST AT MANHOLE OR CLEANOUT

GENERAL NOTES:

1. "ALL" MARKER POSTS SHALL BE SET IN CONCRETE, AS SHOWN.
2. POSTS SHALL BE PAINTED WHITE.
3. REQUIRED FOR "ALL" MANHOLES AND CLEANOUTS LOCATED IN OFF-SITE AREAS. EXCLUDES SHOULDERS OF ROADS, OR OTHER UNIQUE LOCATIONS AS DETERMINED BY THE CITY.
4. INSTALL MARKER AS SHOWN, BETWEEN ROAD AND MANHOLE OR CLEANOUT.

CITY OF TROUTDALE

*SANITARY & STORM,  
MANHOLES AND  
CLEANOUTS  
MARKER POST*

DATE:

UPDATED 1997

DRAWING NO.

VIII - 8

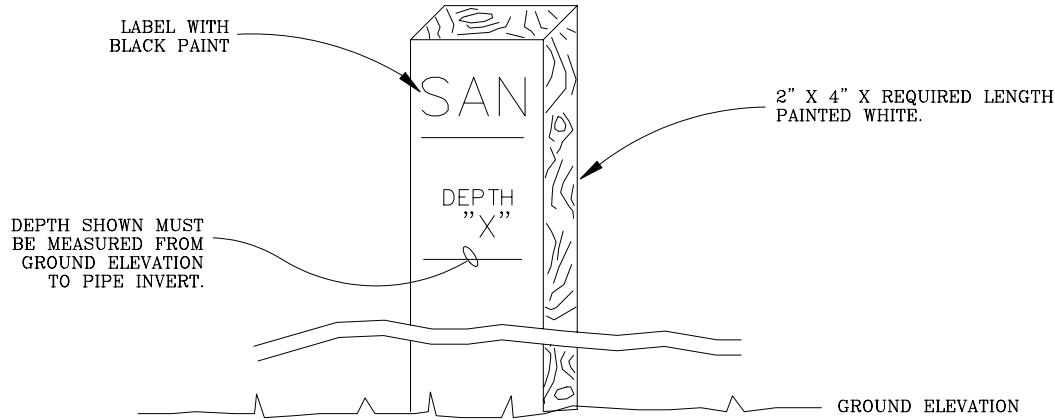

2x4 MARKER LABELS

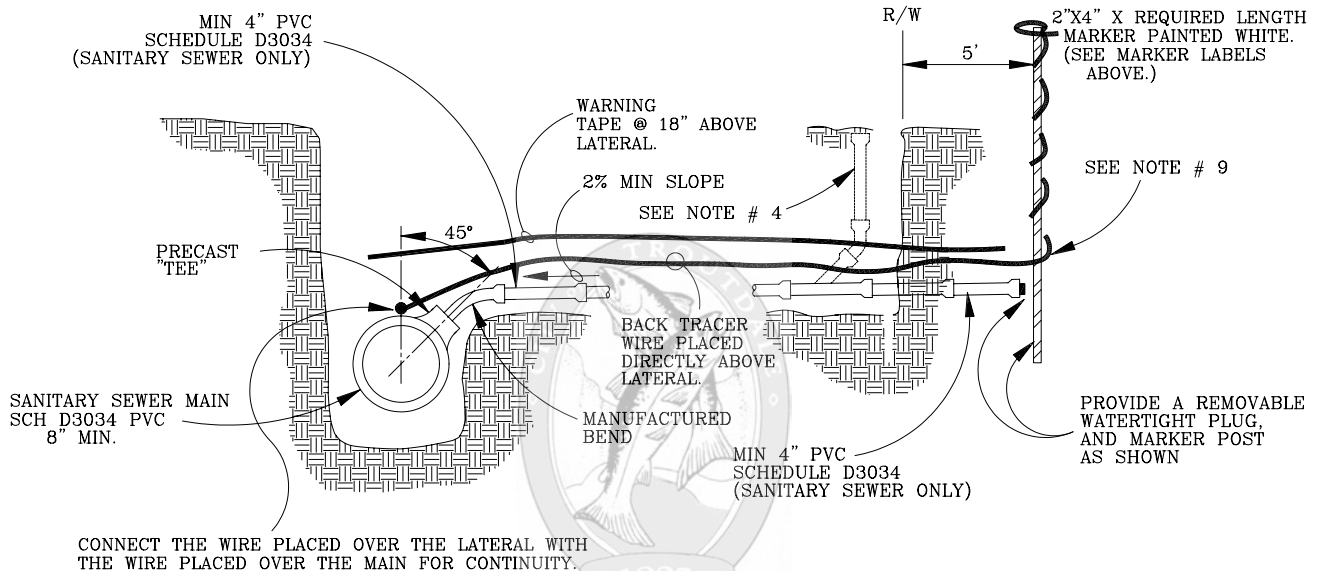

SHALLOW TRENCH SANITARY LATERAL.  
(USED FOR DEPTHS OF 4' TO 9')

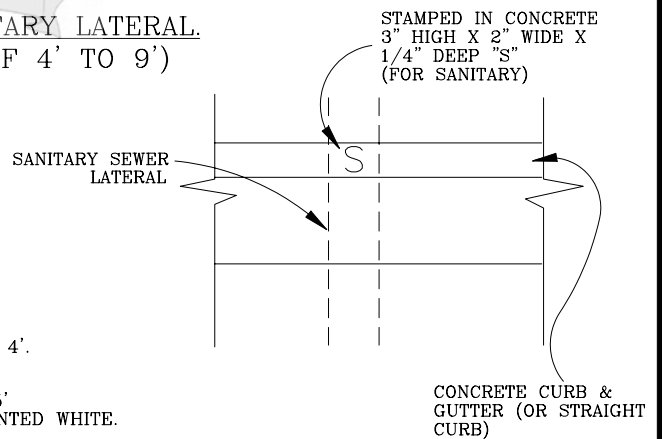

GENERAL NOTES:

1. PIPE AND FITTINGS SHALL BE COMPATIBLE. ONLY MANUFACTURED FITTINGS SHALL BE USED.
2. MINIMUM DEPTH AT RIGHT-OF-WAY OR EASEMENT LINE SHALL BE 4'.
3. MARKER POSTS SHALL BE TREATED WOOD. POST SHALL BE 2" x 4" X REQUIRED LENGTH, FIR. POST TO EXTEND 5' MINIMUM ABOVE FINISH GRADE AND EXPOSED AREA SHALL BE PAINTED WHITE.
4. WHEN REQUIRED, A CLEANOUT SHALL BE INSTALLED @ 100' INTERVALS.
5. MARK ALL SANITARY LATERALS WITH A GREEN "S" (FOR SANITARY) ON FACE OF CURB WHERE LATERAL CROSSES CURB.
6. IN ADDITION TO NOTE #5 ABOVE, STAMP (IN THE CONCRETE) A 3" HIGH BY 2" WIDE BY 1/4" DEEP "S" (FOR SANITARY) ON TOP OF THE CURB WHERE THE LATERAL CROSSES THE CURB.
7. LATERALS SHALL NOT BE BACKFILLED PRIOR TO INSPECTION BY THE CITY.
8. VERTICAL DROP INTO SANITARY MAIN IS NOT PERMITTED.
9. FLAT "T'S" MUST BE APPROVED BY THE CITY.
10. INSTALL #10 TRACER COPPER WIRE DIRECTLY OVER LATERAL & RAP AROUND 2" X 4" MARKER AS SHOWN. TRACER TAPE MUST ALSO BE INSTALLED 18" ABOVE THE PIPE.
11. AN "ELECTRICAL CONTINUITY" TEST WILL BE REQUIRED UPON COMPLETION AND BEFORE FINAL ACCEPTANCE.

CITY OF TROUTDALE

**SANITARY  
SEWER LATERAL  
AND MARKER  
(SHALLOW TRENCH)**

DATE:  
UPDATED 1997

DRAWING NO.  
VIII - 9

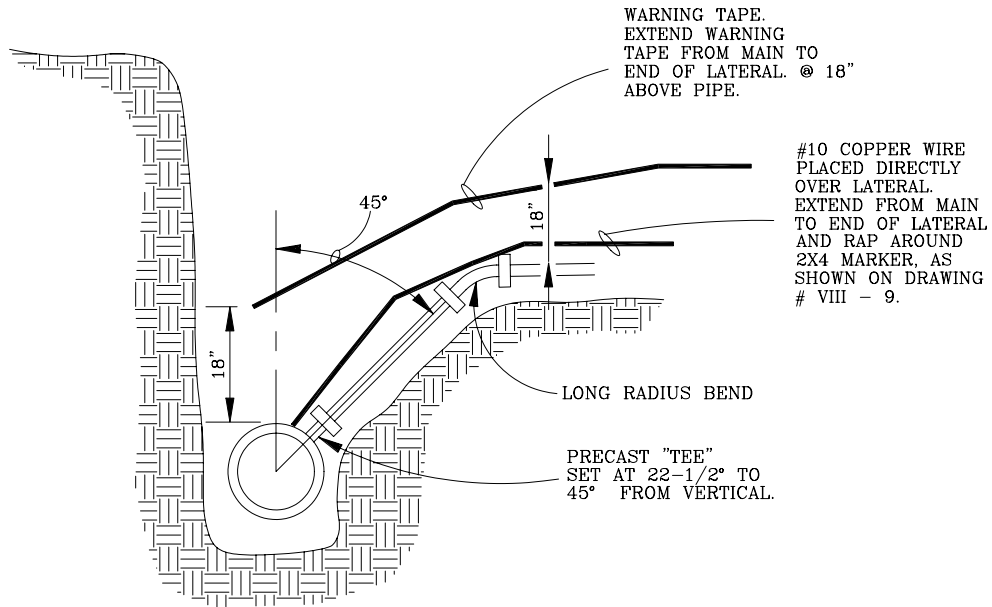

45° TAP TO MAIN  
(USED FOR DEPTHS OF 10' TO 14')

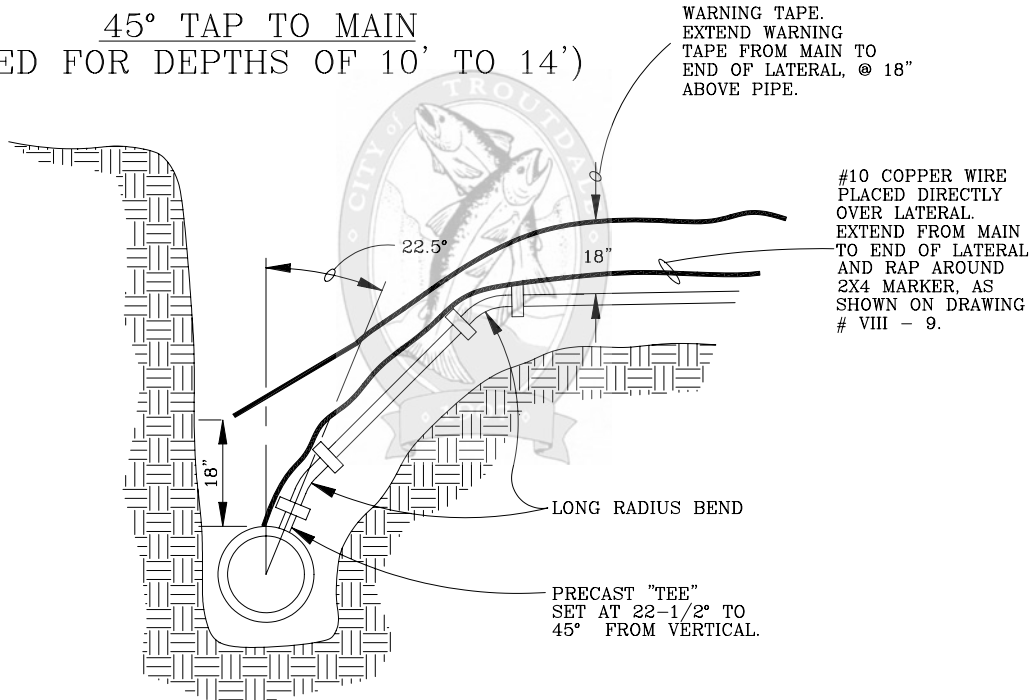

22.5° TAP TO MAIN  
(USED FOR EXTREME DEPTHS OF 15' OR > )

GENERAL NOTES:

1. PIPE AND FITTINGS SHALL BE COMPATIBLE.
2. MINIMUM DEPTH AT RIGHT-OF-WAY OR EASEMENT LINE SHALL BE 4'.
3. PLUGGING, AND MARKING OF UNCONNECTED SERVICES SHALL CONFORM TO DRAWING # VIII - 9, SANITARY SEWER LATERAL AND MARKER (SHALLOW TRENCH)
4. SEE ADDITIONAL NOTES ON DRAWING # VIII - 9 (SHALLOW TRENCH SERVICE) FOR DETAILS ON MARKER AND OTHER GENERAL REQUIREMENTS.

CITY OF TROUTDALE

*SANITARY SEWER  
LATERAL  
(DEEP TRENCH)*

DATE:

UPDATED 1997

DRAWING NO.

VIII - 10

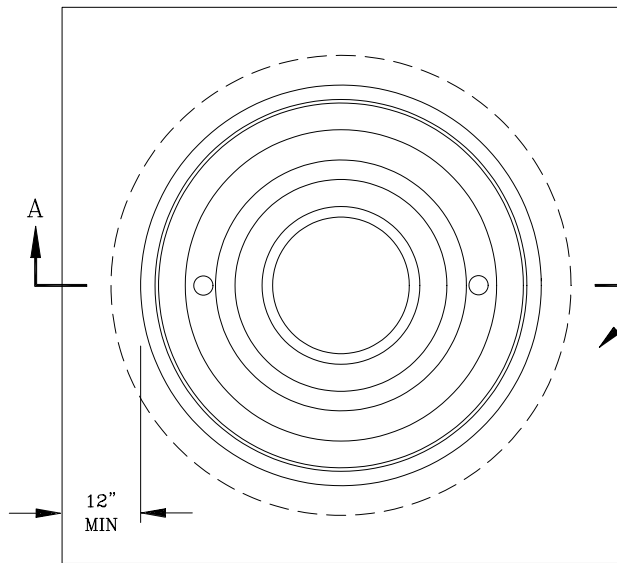

SAW CUT SQUARE AND REMOVE PAVEMENT 2" MIN. LARGER THAN MANHOLE FRAME DIMENSION.

REPLACE WITH 3" THICK CLASS "C" MIX A.C. OR CONCRETE AS REQUIRED BY CITY.

APPLY TACK COAT TO EDGES OF EXISTING PAVEMENT BEFORE INSTALLING PATCH. FINISH JOINT WITH ASPHALTIC SEAL AND SAND.

PLAN VIEW

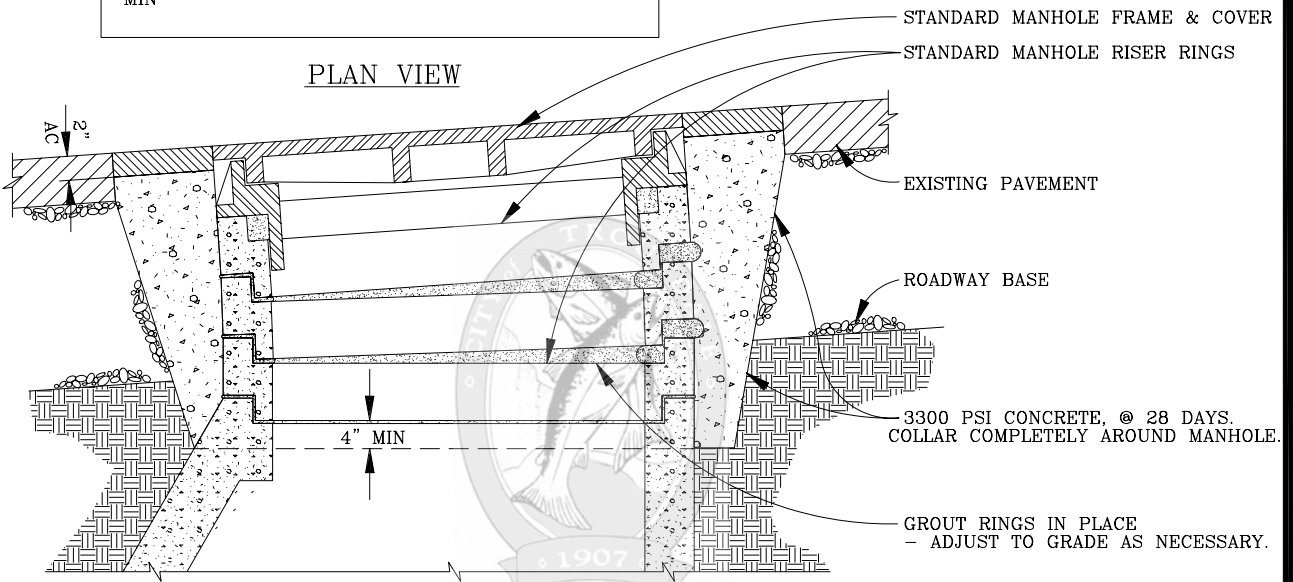

STANDARD MANHOLE FRAME & COVER  
STANDARD MANHOLE RISER RINGS

EXISTING PAVEMENT

ROADWAY BASE

3300 PSI CONCRETE, @ 28 DAYS. COLLAR COMPLETELY AROUND MANHOLE.

GROUT RINGS IN PLACE - ADJUST TO GRADE AS NECESSARY.

SECTION A-A

TYPICAL MANHOLE GRADE ADJUSTMENT IN STREET

GENERAL NOTES:

1. 2 HOLE LIDS FOR SANITARY.
2. 16 HOLE LIDS FOR STORM.
3. TOTAL DEPTH OF RINGS SHALL NOT EXCEED 10".

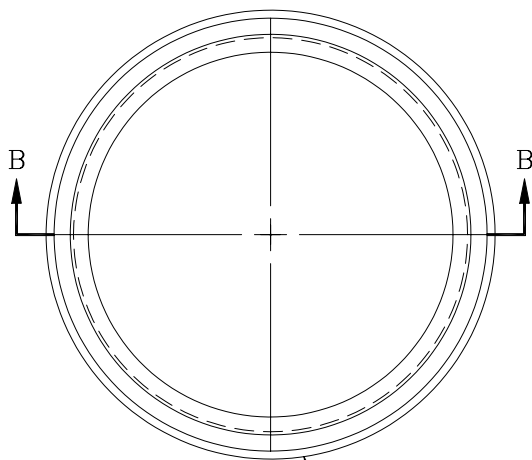

MATERIAL SHALL BE ALUMINUM ALLOY 319.2, 356.2 OR A-360.

MANHOLE ADJUSTMENT RINGS FOR RESURFACING

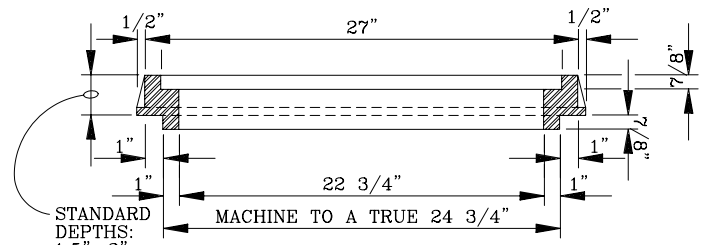

SECTION B-B

CITY OF TROUTDALE

MANHOLE RING ADJUSTMENTS (SANITARY & STORM)

DATE: UPDATED 1997

DRAWING NO. VIII - 11

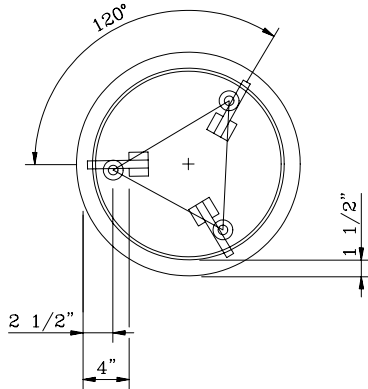

GENERAL:  
 BOLTS TO BE FURNISHED WITH STANDARD  
 HEX-HEAD NUTS & COTTER KEYS. COVER  
 AND RING TO BE MACHINED TO A TRUE  
 BEARING AT CONTACT POINTS.

PLAN VIEW

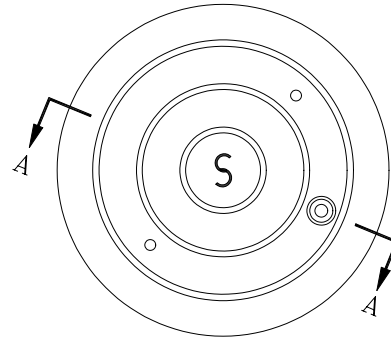

PLAN VIEW

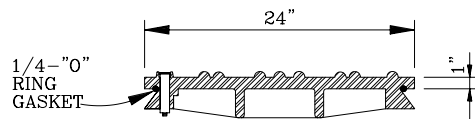

COVER SECTION

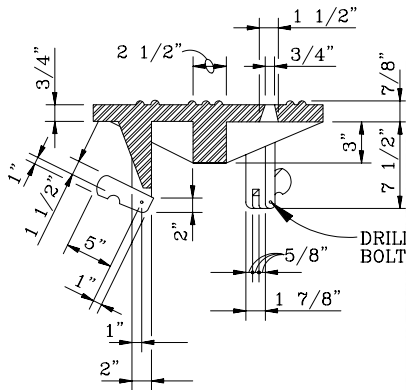

COVER SECTION

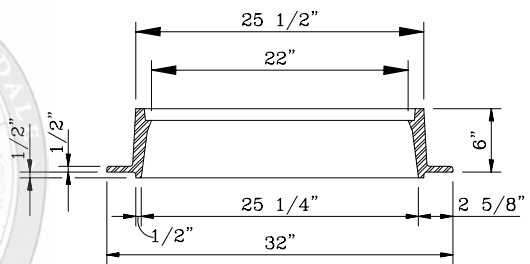

SECTION A-A

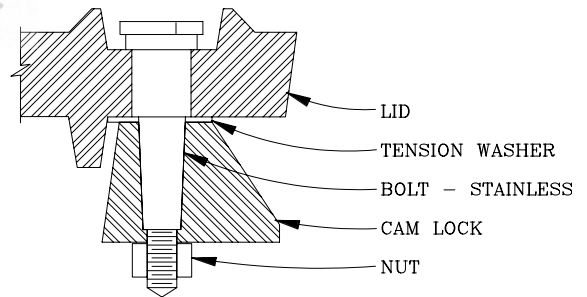

CAM-LOCK ASSEMBLY

STANDARD CAM-LOCK ALUMINUM  
 FRAME AND COVER  
 (SANITARY AND STORM)

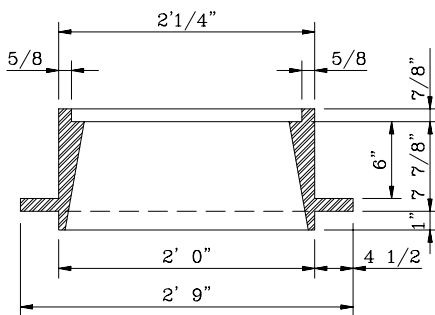

FRAME SECTION

STANDARD CAM-LOCK CAST  
 IRON FRAME AND COVER

GENERAL NOTES:

1. CITY WILL DETERMINE WHEN THESE LIDS WILL BE REQUIRED, ON A "PER PROJECT" BASIS.

CITY OF TROUTDALE

CAM-LOCK MANHOLE COVER  
 AND FRAME DETAILS  
 (CAST IRON AND ALUMINUM)

DATE:  
 UPDATED 1997

DRAWING NO.  
 VIII - 12

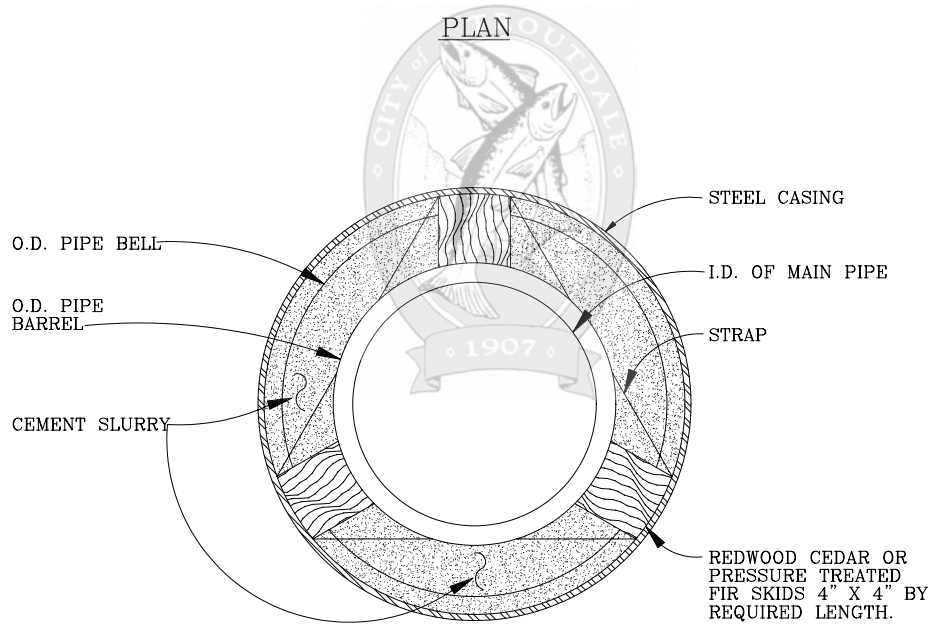
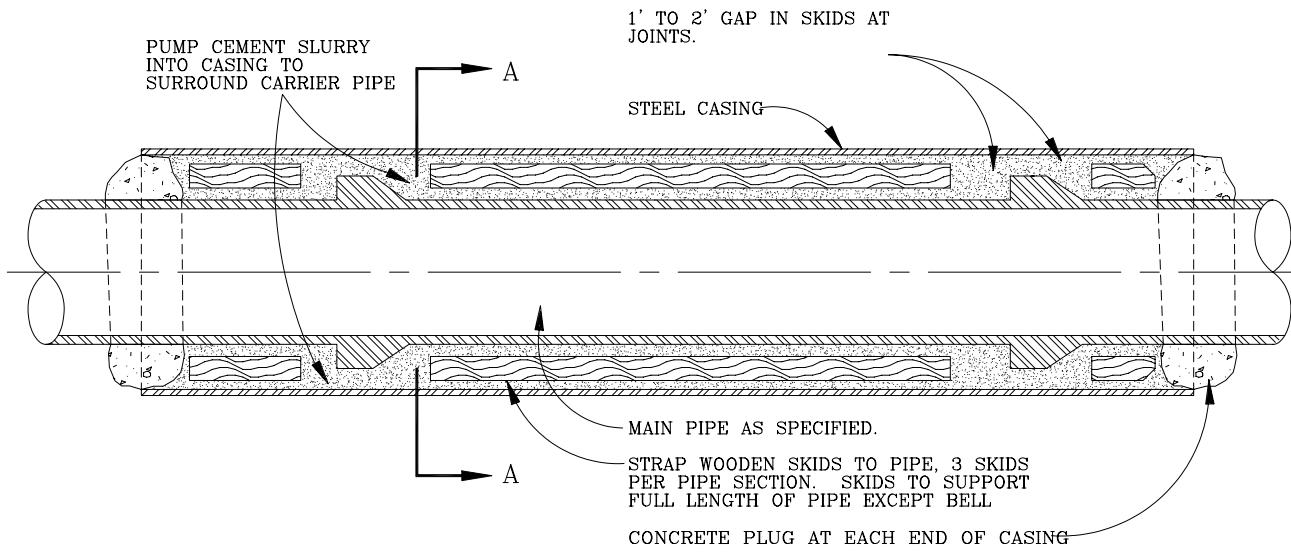

SECTION A-A

- GENERAL NOTES:**
1. PLUG ENDS OF CASING WITH CONCRETE, AS SHOWN.
  2. A LOCATE REQUEST FOR ALL PUBLIC AND PRIVATE UTILITIES IS REQUIRED PRIOR TO BORE.
  3. ALL INSTALLATIONS MUST BE WITNESSED BY CITY FORCES.

CITY OF TROUTDALE	
<i>BORE CASING DETAIL</i>	
DATE: UPDATED 1997	DRAWING NO. VIII - 13

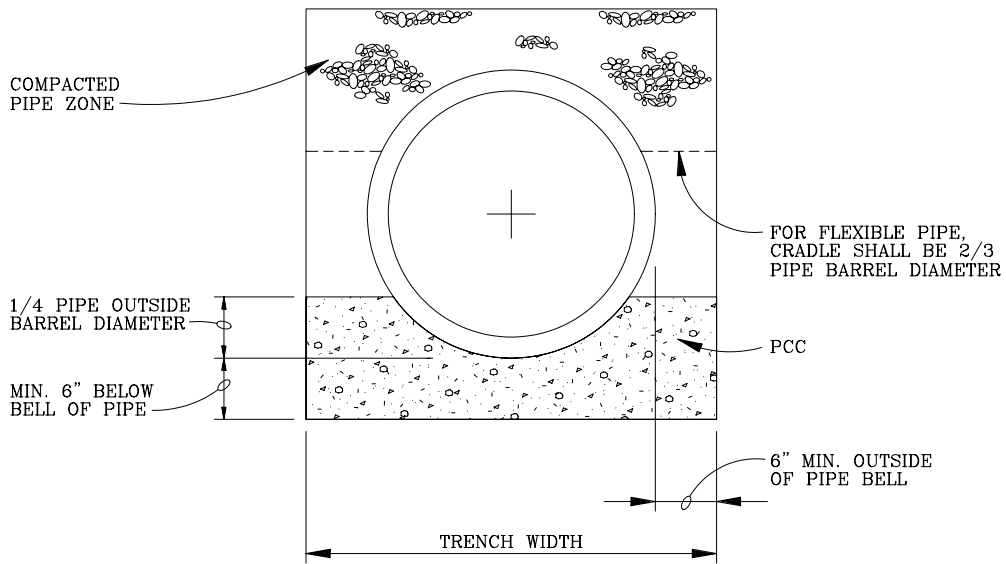

ENCASEMENT DETAIL

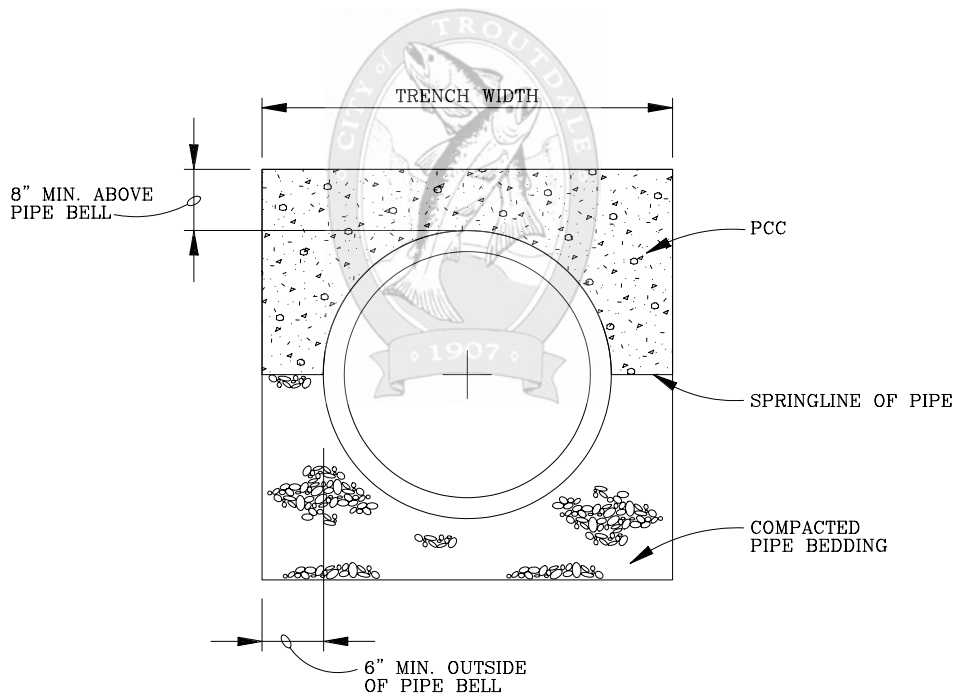

CAP DETAIL

GENERAL NOTES:

1. CONCRETE SHALL BE 3000 PSI, @ 28 DAYS.
2. CITY TO DETERMINE WHEN REQUIRED, ON A "PER PROJECT" BASIS.
3. APPLIES TO SANITARY, STORM AND WATER MAINS.

CITY OF TROUTDALE

*CONCRETE CRADLE  
AND CAP DETAILS*

DATE:  
UPDATED 1997

DRAWING NO.  
VIII - 14

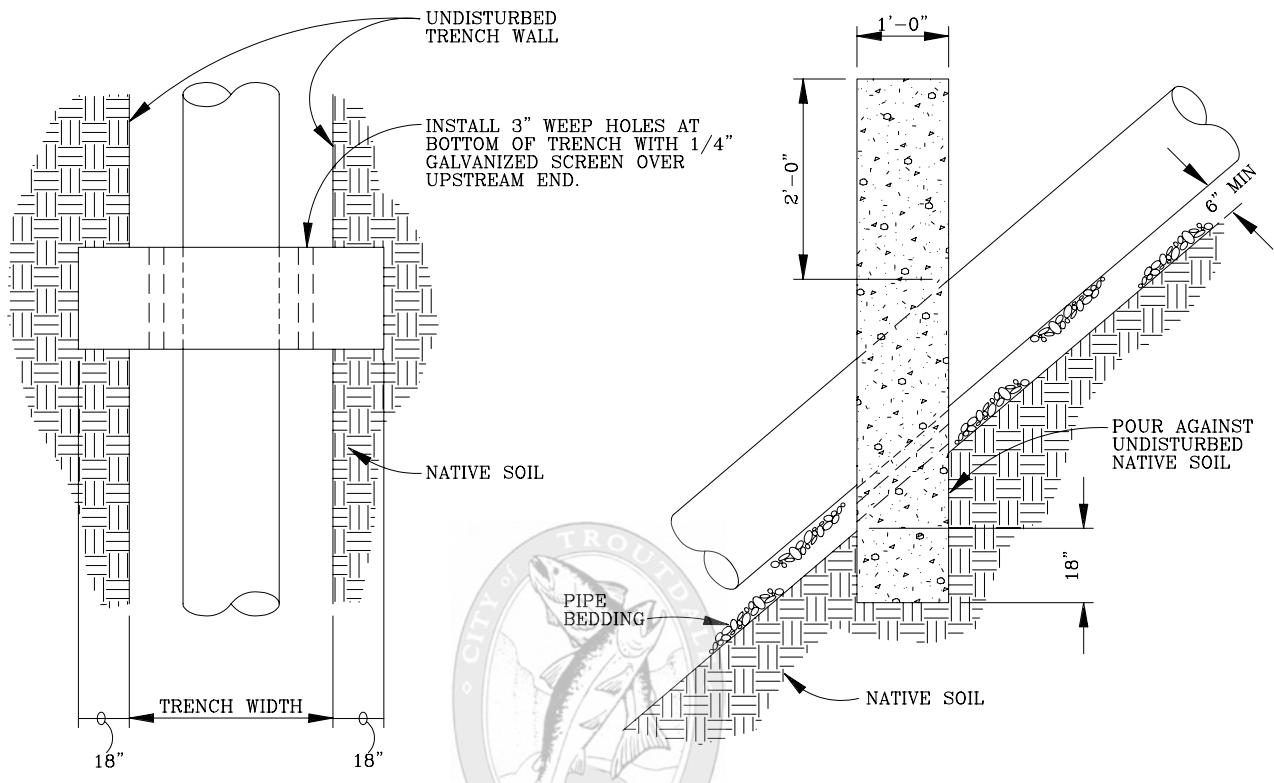

**GENERAL NOTES:**

1. CONCRETE ANCHOR WALLS (3300 PSI, @ 28 DAYS) SHALL BE CONSTRUCTED USING FORMS WHEN SEWERS, STORM DRAINS, AND OTHER PIPELINES ARE CONSTRUCTED WITH SLOPES 20 PERCENT OR GREATER. REMOVE FORMS PRIOR TO BACKFILLING TRENCH.
2. SPACING OF ANCHOR WALLS SHALL BE:
 

SLOPE:	SPACING:
20-34%	35 FEET
35-50%	25 FEET
50+ %	15 FEET OR CONCRETE ENCASEMENT
3. VISUAL INSPECTION BY CITY FORCES IS REQUIRED PRIOR TO BACKFILLING.
4. APPLIES TO WATER, STORM AND SEWER MAINS.

CITY OF TROUTDALE

*PIPE ANCHOR DETAIL*

DATE:  
UPDATED 1997

DRAWING NO.  
VIII - 15

MANHOLE LID, SANITARY AND/OR STORM  
SEWER CLEAN OUT, WATER VALVE BOX, WATER  
METER BOX, BLOW OFF ASSEMBLY, ETC.

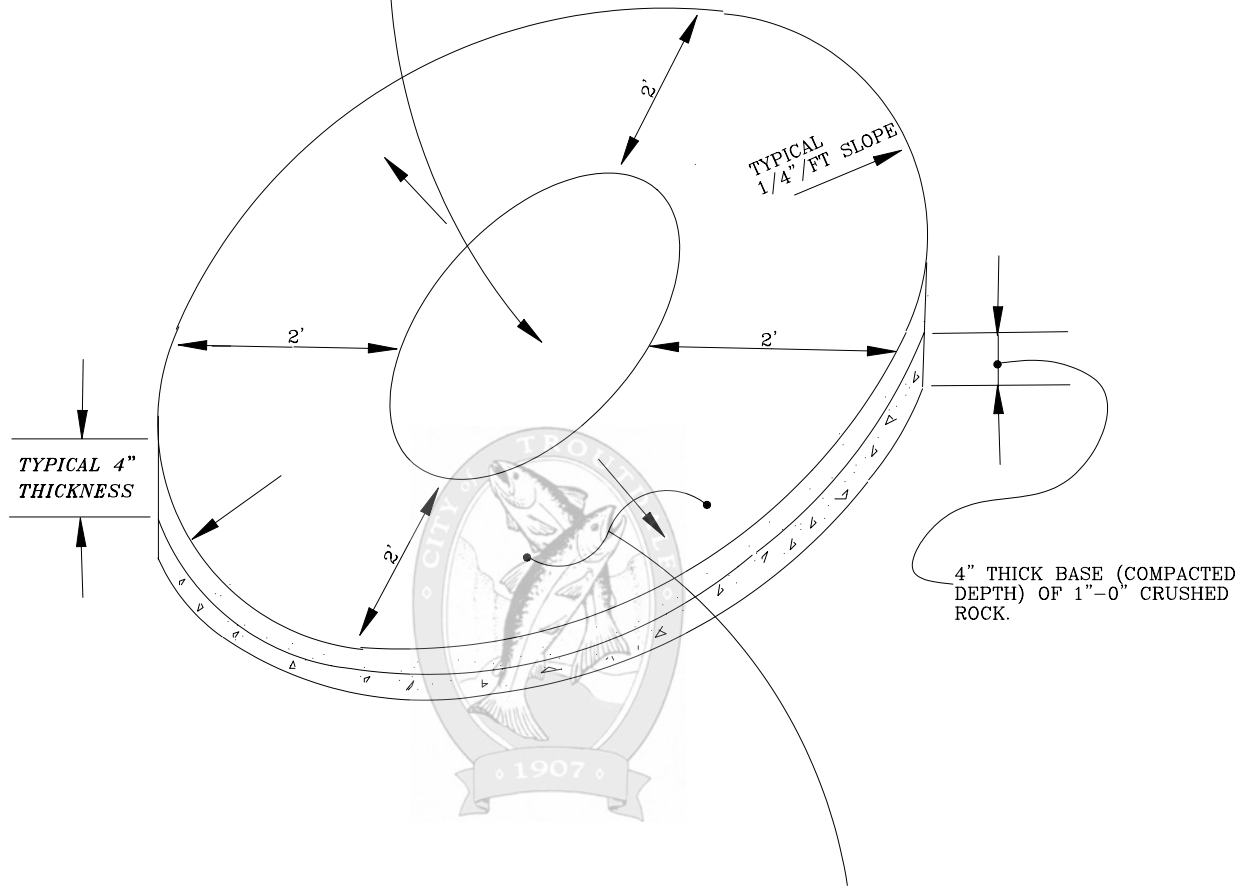

CONCRETE APRON IS REQUIRED WHEN CENTER STRUCTURE IS LOCATED IN UNPAVED ROAD SHOULDERS, OTHER AREAS OR AS REQUIRED BY THE CITY.

GENERAL NOTES:

1. USE 3000 PSI CONCRETE @ 28 DAYS.
2. DETAIL APPLIES TO WATER, SANITARY AND STORM UTILITY STRUCTURES.

CITY OF TROUTDALE

*CONCRETE  
APRON*

DATE:  
UPDATED 1997

DRAWING NO.  
VIII - 16